

Small Part Manufacturing

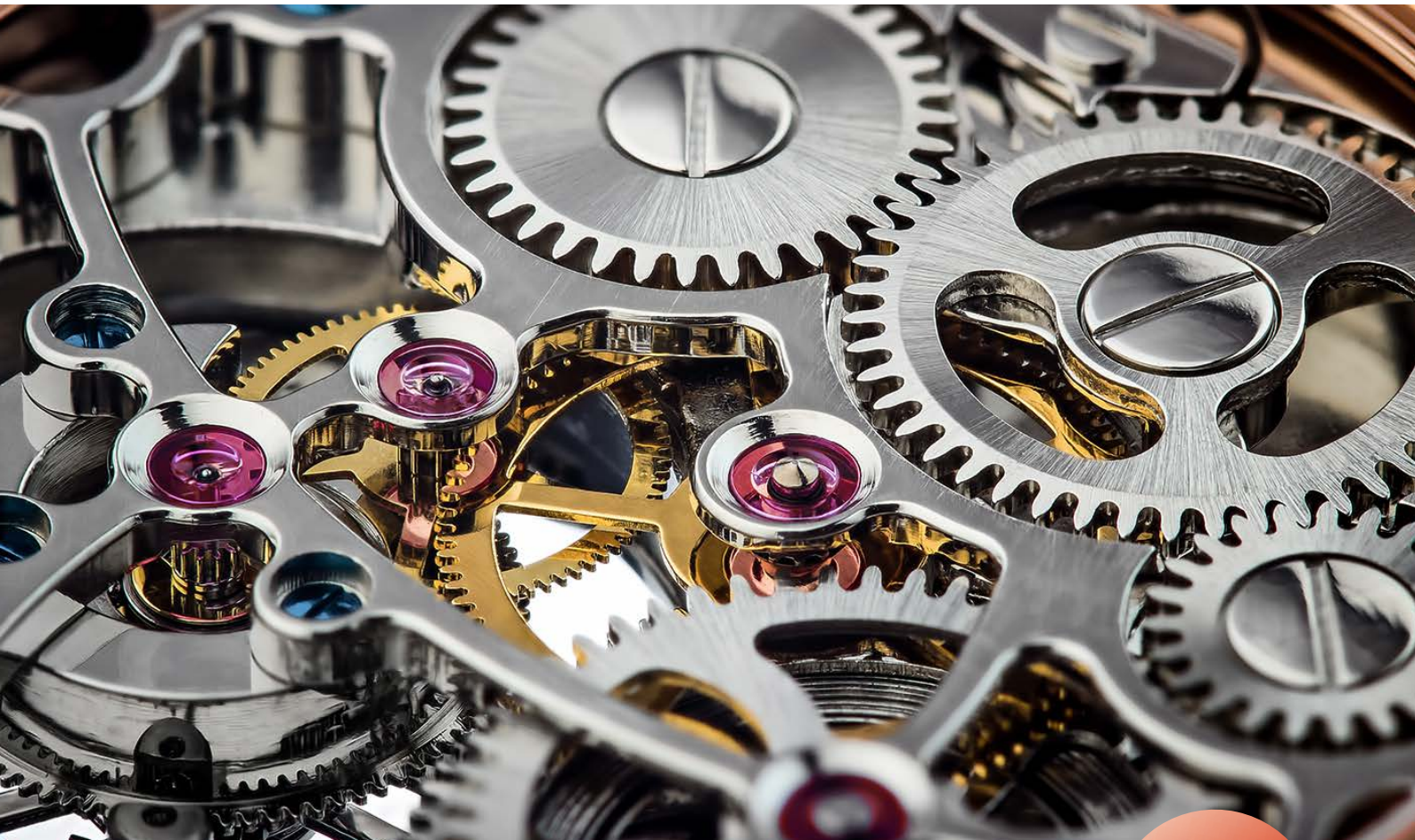

ETP HYDRO-GRIP® PENCIL

HSK40
A & E

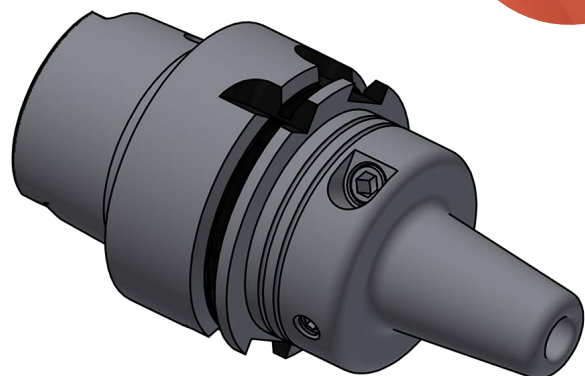
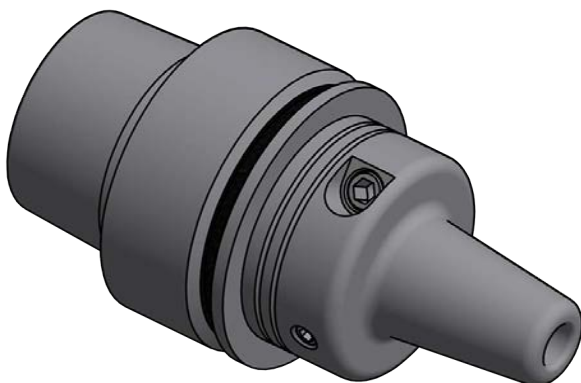

BENEFITS & FEATURES

- High run-out accuracy $\leq 0,004$ mm.
- Easy handling and tool change.
- High clamping force.
- Vibration dampening.
- Flexibility in clamping range
– use of reduction sleeves possible.



EASY MOUNTING WITH
TORQUE WRENCH



HIGH RUNOUT ACCURACY



DAMPING



FAST SET-UP TIME

ETP HYDRO-GRIP® PENCIL

HSK Form A

707080 ETP HYDRO-GRIP PENCIL 6x25/HSK40A

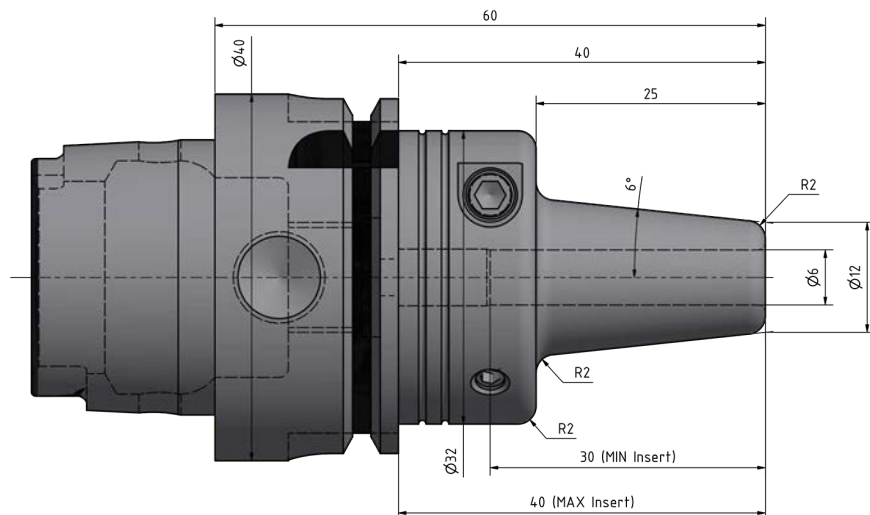

ETP HYDRO-GRIP® PENCIL

HSK Form E

706903 ETP HYDRO-GRIP PENCIL 6x25/HSK40E

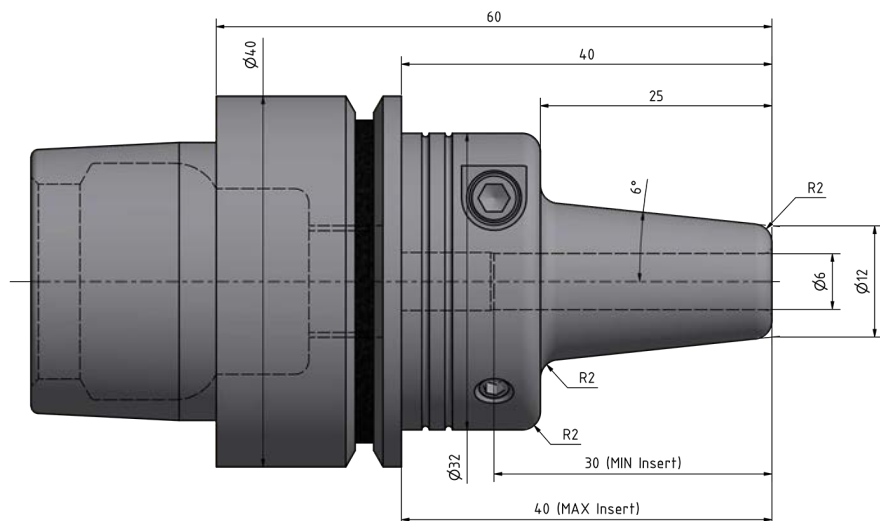

Information:

- Runout accuracy < 0.004 mm at 2.5 x dmt (max. 50 mm)
≤ 0.00016 inch at 2.5 x dmt (max. 1.969 inch)
- Tool shank h6 or h7 can be used
- Coolant through on all holders
- Bore for data carrier on HSK40A

Accessories:

Use preset Torque Wrench, 1.8 Nm, to ensure correct mounting of tools. Part no. 19070

ETP HYDRO-GRIP can be used with reducing sleeves.
For additional information see section Accessories.

