

ETP HYDRO-FIX®

Hydraulic high precision clamping holders

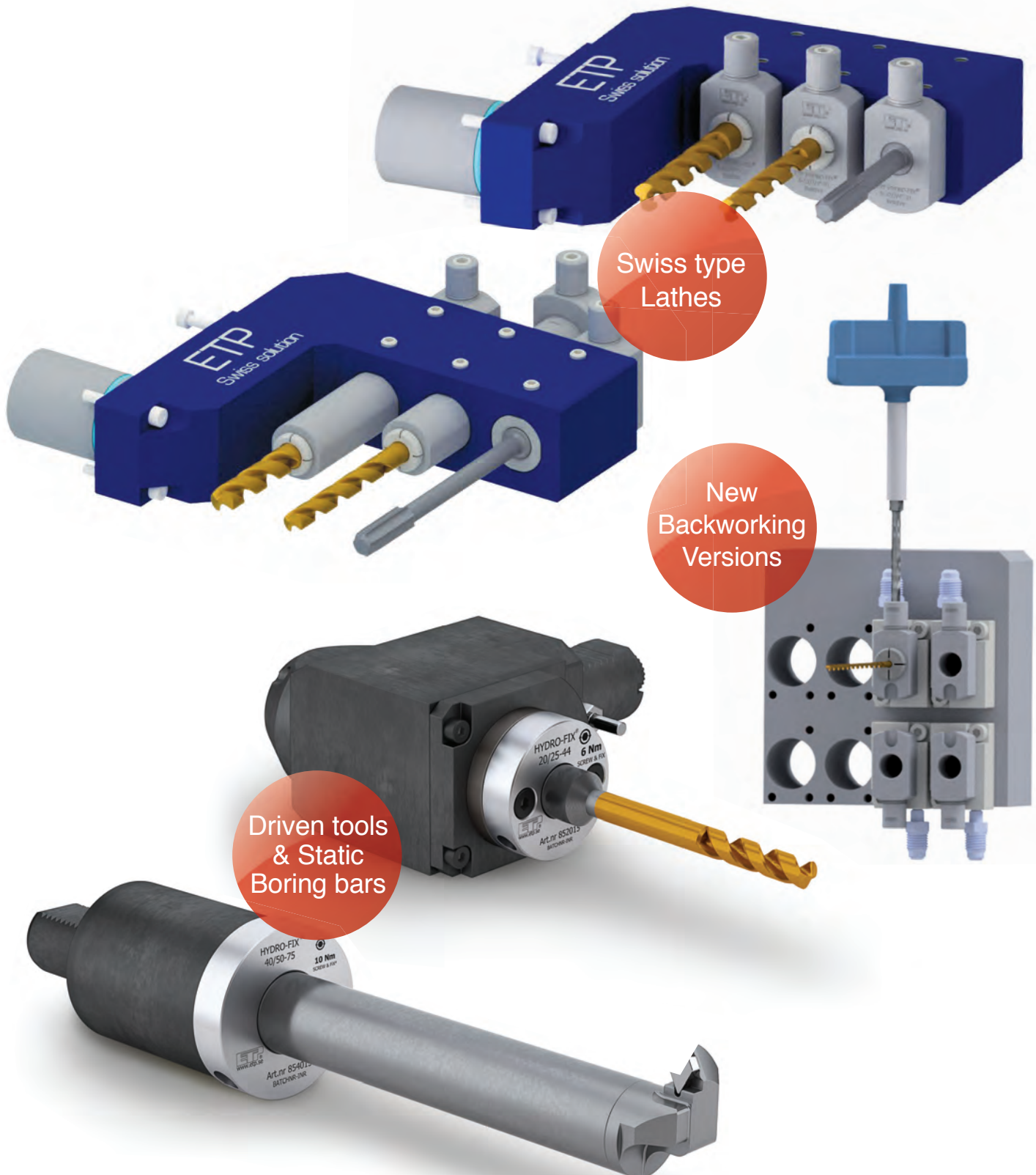



ETP HYDRO-FIX S[®]

Hydraulic high precision clamping holders

Increases your productivity!



ETP HYDRO-FIX S clamping holders are excellent for static front and back operations such as drilling, reaming and boring. With the one screw fix system it is quick and easy to handle. Precision hydraulic tool centering is achieved and therefore the tool life and setup time is improved.

The clamping holders allows for larger/deeper drilling, quick tool changes, absorbs/reduces vibration, improves surface quality and best of all: increases your productivity!

Static front & back working tools

BENEFITS & FEATURES

- Replaces ER11 – ER32 collet holders
- Use larger and longer tools
- Shank clamping range: 1 to 25 mm and 1/8" to 13/16" using reduction sleeves
- Quick and easy handling
- Reduced vibrations
- Improved surface quality
- Increased tool life

Designs

Cylindrical

Hydraulic clamping on the tool shank and expansion of the holder inside the machine block!

Perfect centering



Flat

Hydraulic clamping on the tool shank!

Easy length adjustability



What some of our clients say

”

ETP Transmission has brought our deep hole drilling capabilities to a completely new level.

Nick Hamel
Computer Numerical Control
Programmer at Mount Mfg.



ETP SWISS Toolholders - “a game changer” at Mount Mfg

The medical device manufacturing company Mount MFG reached out to ETP Transmission with the hopes to streamline and improve their workflow within swiss turning.

A couple of months later the manufacturing company can say that the result is beyond their expectations.

”

The versatility offered by ETP is amazing and from a safety perspective, these holders allow effortless tool changes in tight spaces without the wrenches slipping off. I can't wait to see what they produce next.

Seth Nickerson
Machine Technician Autocam Medical



Medical Manufacturer Autocam Medical Chooses ETP – Requires the Best of the Best Tooling for Extremely Tight Tolerances

The leading medical manufacturer, Autocam Medical, requires extreme precision to make their products, later used by a very demanding industry that performs life-changing

procedures. In February, the company made their first purchase of ETP HYDRO-FIX SWISS® and the versatility of the product makes them return, over and over again.

ETP HYDRO-FIX SFC®

Front activation – Cylindrical design

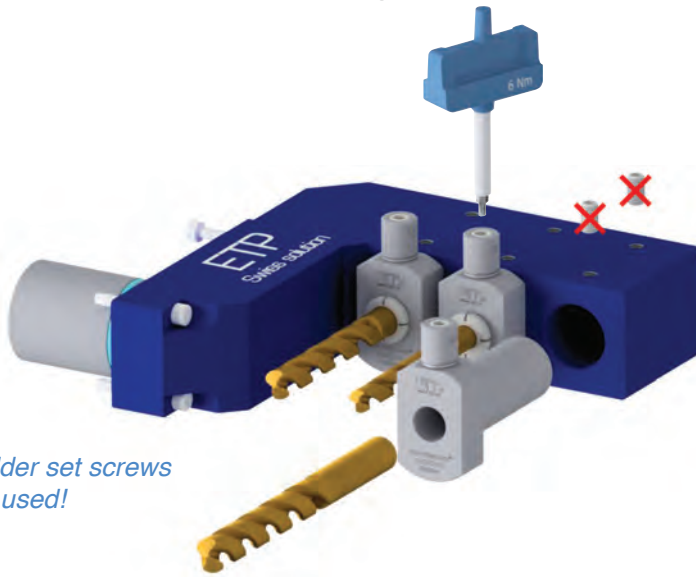

Block/holder set screws are **NOT** used!



Perfect centering

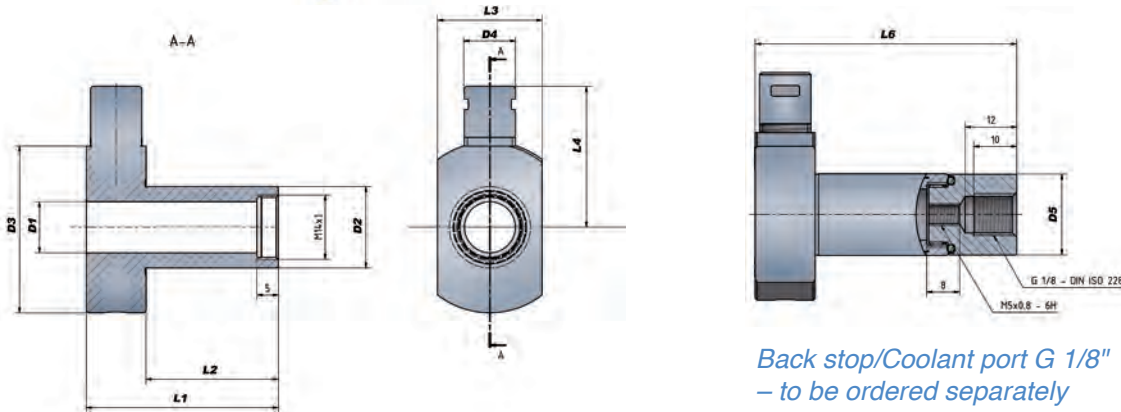

Back stop/Coolant port G 1/8" – to be ordered separately

Technical Specification

Part no.	Item description	Dimensions, mm								Dimensions with Back stop/Coolant port G 1/8"		
		D1*	D2**	D3	D4	L1	L2	L3	L4	L6	D5	Part no. - Back stop/Coolant port G 1/8" Includes adjustment screw M5x0.8-16***
670000	HYDRO-FIX SFC-12/16-24	12	16	33	12	38	24	18.5	30.5			
664090	HYDRO-FIX SFC-12/3/4"-31	12	19.05	40	12	45	31	21.5	33	61	18.85	664000-10
664100	HYDRO-FIX SFC-12/20-31	12	20	40	12	45	31	22.5	33	61	18.85	664000-10
663740	HYDRO-FIX SFC-12/22-31	12	22	40	12	45	31	24.5	33	61	18.85	664000-10
664110	HYDRO-FIX SFC-12/25-31	12	25	40	12	45	31	27.5	33	61	18.85	664000-10
664120	HYDRO-FIX SFC-12/1"-31	12	25.4	40	12	45	31	27.5	33	61	18.85	664000-10
663750	HYDRO-FIX SFC-20/25-30*	20	25	44	12	44	30	27.5	35			
664130	HYDRO-FIX SFC-20/1"-30*	20	25.4	44	12	44	30	27.5	35			
664140	HYDRO-FIX SFC-25/1 1/4"-34*	25	31.75	50	12	48	34	34.5	38			
663760	HYDRO-FIX SFC-25/32-34*	25	32	50	12	48	34	34.5	38			

*) These sizes are **NOT** threaded with an M14x1 for a Back stop/coolant port. Pressure screw angled 15°.



Information:

- *) Tool/toolbar shank h6 or h7 can be used.
- **) Recommended tolerance of toolholder bore - H7.
- ***) Adjustment screw M5x0.8-16 can also be ordered separately as spare part. Part no. S041

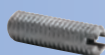

Accessories:

Use preset Torque Wrench to ensure correct mounting of tools. 6 Nm - Part no. 19055



ETP HYDRO-FIX can be used with reduction sleeves. For additional information see section Accessories.



Adaptors:

Male G 1/8" to Female 1/8" NPT Part no. 19151



Male G 1/8" to Male 1/4" JIC Part no. 19150

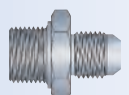

ETP HYDRO-FIX SFF®

Front activation – Flat design

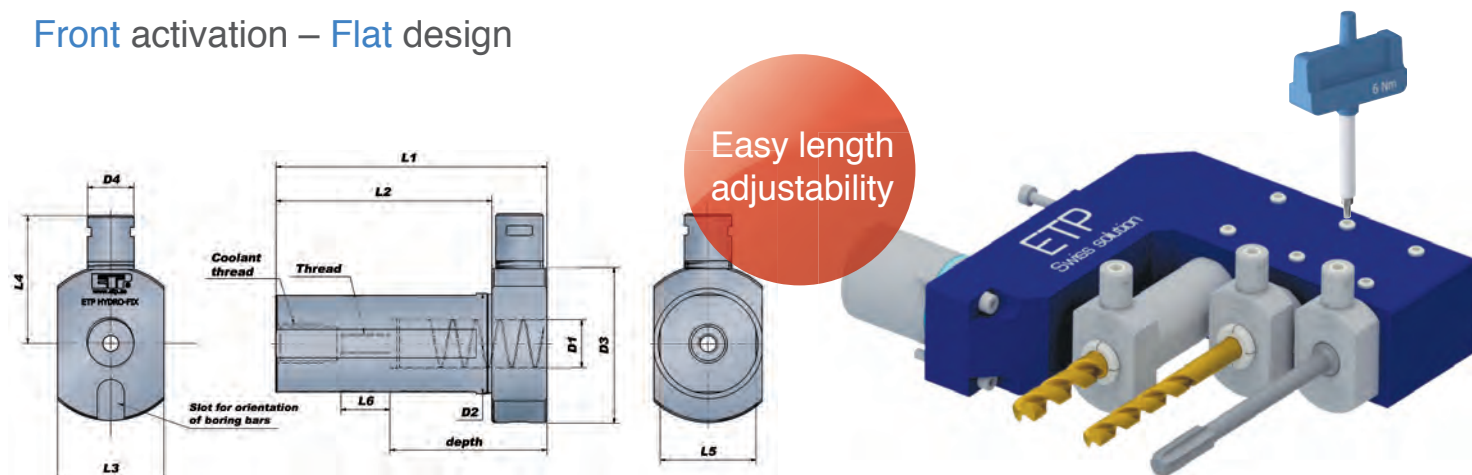

Set screws are used to clamp on the milled flat, after adjusting the length of the assembly.

Technical Specification		Dimensions, mm												
Part no.	Item description	D1	D2	D3	D4	L1	L2	depth	L3	L4	L5	Thread	L6	Coolant thread DIN ISO 228
706010	HYDRO-FIX SFF-12/3/4"-50	12	19.05	40	12	64	50	40	21.5	33	18.05	M5x0.8 - 6H	7	G 1/8
706158	HYDRO-FIX SFF-12/3/4"-75	12	19.05	40	12	89	75	40	21.5	33	18.05	M5x0.8 - 6H	16	G 1/8
706159	HYDRO-FIX SFF-12/20-75	12	20	40	12	89	75	40	22.5	33	19	M5x0.8 - 6H	16	G 1/8
706012	HYDRO-FIX SFF-12/25-150	12	25	40	12	164	150	40	27.5	33	24	M5x0.8 - 6H	16	G 1/8
706053	HYDRO-FIX SFF-12/1"-55	12	25.4	40	12	69	55	40	27.5	33	24.4	M5x0.8 - 6H	12	G 1/8
706011	HYDRO-FIX SFF-12/1"-100	12	25.4	40	12	114	100	40	27.5	33	24.4	M5x0.8 - 6H	16	G 1/8



Hydraulic clamping against tool

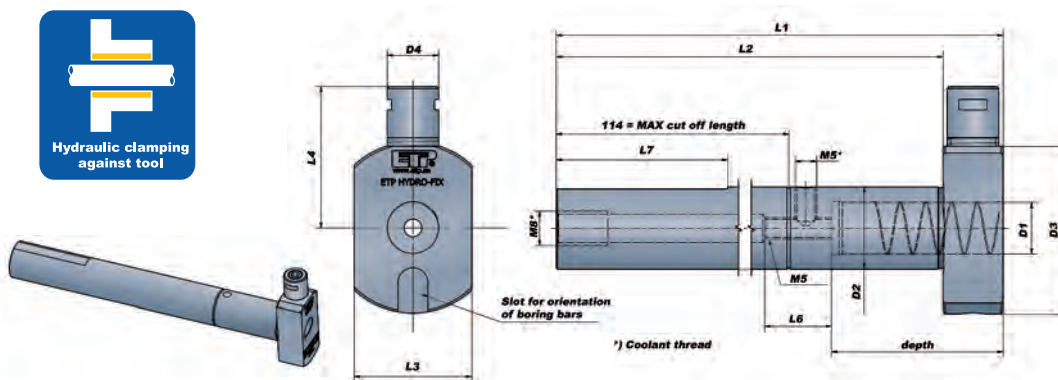

Cut to length

With the below range of SFF versions you have the possibility to cut your holder to a desired length!

Technical Specification		Dimensions, mm												
Part no.	Item description	D1	D2	D3	D4	L1	L2	depth	L3	L4	L7	Thread	L6	
664200	HYDRO-FIX SFF-12/3/4"-150	12	19.05	40	12	164	150	40	19.5	33	40	M5x0.8 - 6H	16	
664210	HYDRO-FIX SFF-12/20-150	12	20	40	12	164	150	40	22.5	33	40	M5x0.8 - 6H	16	
664220	HYDRO-FIX SFF-12/22-150	12	22	40	12	164	150	40	24.5	33	40	M5x0.8 - 6H	16	
664230	HYDRO-FIX SFF-12/25-150	12	25	40	12	164	150	40	27.5	33	40	M5x0.8 - 6H	16	
664240	HYDRO-FIX SFF-12/1"-150	12	25.4	40	12	164	150	40	27.5	33	40	M5 x0.8 - 6H	16	

Information:

*) Tool/toolbar shank h6 or h7 can be used.
 **) Recommended tolerance of toolholder bore - H7.
 Adjustment screw M5x0.8-16 included in shipment. It can also be ordered separately as spare part. Part no. S041



Accessories:

Use preset Torque Wrench to ensure correct mounting of tools. 6 Nm - Part no. 19055



ETP HYDRO-FIX can be used with reduction sleeves. For additional information see section Accessories.



Adaptors:

Male G 1/8" to Female 1/8" NPT Part no. 19151
 Male G 1/8" to Male 1/4" JIC Part no. 19150
 Male M8x1.25 to Male 1/4" JIC Part no. 19152

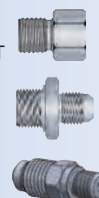

ETP HYDRO-FIX SBF®

Back activation – Flat design



Set screws are used to clamp on the milled flat, after adjusting the length of the assembly.

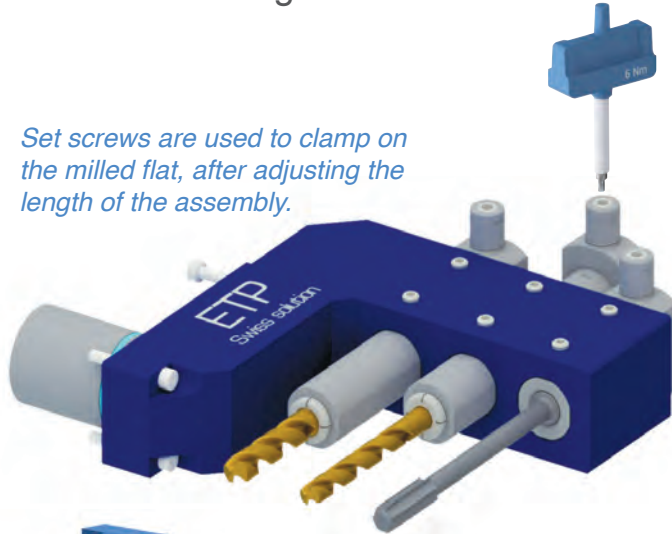

Easy length adjustability

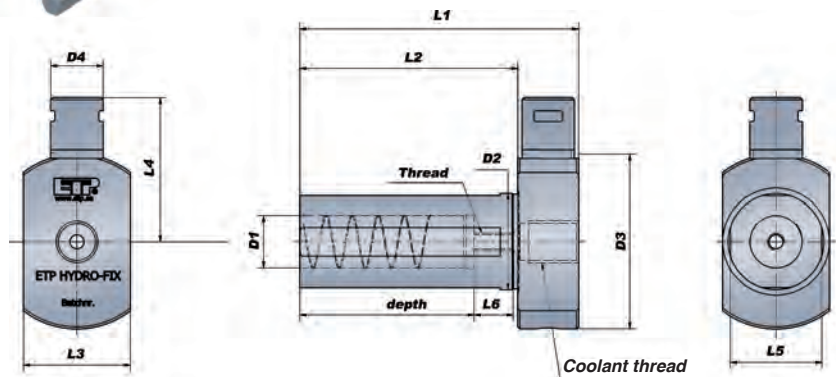
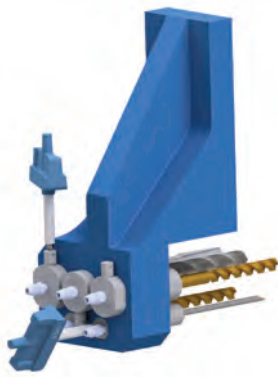

Technical Specification

Part no.	Item description	Dimensions, mm													Thread	L6	Coolant thread DIN ISO 228
		D1	D2	D3	D4	L1	L2	depth	L3	L4	L5	Thread	L6				
664000	HYDRO-FIX SBF-12/3/4"-50	12	19.05	40	12	64	50	40	21.5	33	21	M5x0.8 - 6H	9	G 1/8			
664010	HYDRO-FIX SBF-12/3/4"-75	12	19.05	40	12	89	75	40	21.5	33	21	M5x0.8 - 6H	10	G 1/8			
664020	HYDRO-FIX SBF-12/3/4"-100	12	19.05	40	12	114	100	40	21.5	33	21	M5x0.8 - 6H	10	G 1/8			
706337	HYDRO-FIX SBF-12/20-50	12	20	40	12	64	50	40	22.5	33	19	M5x0.8 - 6H	7	G 1/8			
664030	HYDRO-FIX SBF-12/20-75	12	20	40	12	89	75	40	22.5	33	21	M5x0.8 - 6H	10	G 1/8			
664040	HYDRO-FIX SBF-12/20-100	12	20	40	12	114	100	40	22.5	33	21	M5x0.8 - 6H	10	G 1/8			
663700	HYDRO-FIX SBF-12/22-50	12	22	40	12	64	50	40	24.5	33	21	M5x0.8 - 6H	9	G 1/8			
663770	HYDRO-FIX SBF-12/22-75	12	22	40	12	89	75	40	24.5	33	21	M5x0.8 - 6H	10	G 1/8			
663720	HYDRO-FIX SBF-12/22-100	12	22	40	12	114	100	40	24.5	33	21	M5x0.8 - 6H	10	G 1/8			
663780	HYDRO-FIX SBF-12/22-115	12	22	40	12	129	115	40	24.5	33	21	M5x0.8 - 6H	10	G 1/8			
663710	HYDRO-FIX SBF-12/25-50	12	25	40	12	64	50	40	27.5	33	24	M5x0.8 - 6H	9	G 1/8			
663790	HYDRO-FIX SBF-12/25-75	12	25	40	12	89	75	40	27.5	33	24	M5x0.8 - 6H	10	G 1/8			
663730	HYDRO-FIX SBF-12/25-100	12	25	40	12	114	100	40	27.5	33	24	M5x0.8 - 6H	10	G 1/8			
664050	HYDRO-FIX SBF-12/1"-50	12	25.4	40	12	64	50	40	27.5	33	24	M5x0.8 - 6H	9	G 1/8			
664060	HYDRO-FIX SBF-12/1"-75	12	25.4	40	12	89	75	40	27.5	33	24	M5x0.8 - 6H	10	G 1/8			
664070	HYDRO-FIX SBF-12/1"-100	12	25.4	40	12	114	100	40	27.5	33	24	M5x0.8 - 6H	10	G 1/8			
664080	HYDRO-FIX SBF-20/32-50	20	32	40	12	64	50	52	34.5	33	30.8	M5x0.8 - 6H	9	-			
663810	HYDRO-FIX SBF-20/32-75	20	32	40	12	89	75	52	34.5	33	30.8	M5x0.8 - 6H	10	G 1/8			
663820	HYDRO-FIX SBF-20/32-100	20	32	40	12	114	100	52	34.5	33	30.8	M5x0.8 - 6H	10	G 1/8			

Information:

*) Tool/toolbar shank h6 or h7 can be used.
 **) Recommended tolerance of toolholder bore - H7.
 Adjustment screw included in shipment.
 Can also be ordered separately as spare part.
 M5x0.8-16 Part no. S041

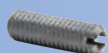

Accessories:

Use preset Torque Wrench to ensure correct mounting of tools.
 6 Nm - Part no. 19055



ETP HYDRO-FIX can be used with reduction sleeves.
 For additional information see section Accessories.



Adaptors:

Male G 1/8" to Female 1/8" NPT Part no. 19151
 Male G 1/8" to Male 1/4" JIC Part no. 19150
 Male M5 to Male 1/4" JIC Part no. 19153



ETP HYDRO-FIX SP[®]

PENCIL – Back activation – Flat design

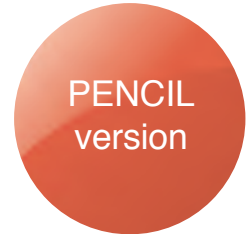
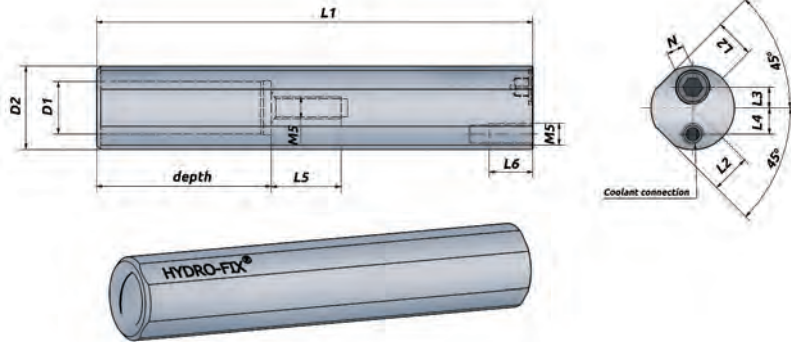

Technical Specification

Part no.	Item description	Dimensions, mm								Center thread		Coolant connection	
		D1	D2	L1	L2	L3	L4	depth	N	size	L5	size	L6
665000	HYDRO-FIX SP-6/16-65*	6	16	65	7.5**	2.7		27	4				
665070	HYDRO-FIX SP-12/3/4"-75***	12	19.05	75	9	4.75	6	40	4	M5	8	M5	10
665010	HYDRO-FIX SP-12/3/4"-100	12	19.05	100	9	4.75	6	40	4	M5	16	M5	10
665080	HYDRO-FIX SP-12/20-75***	12	20	75	9.5	4.75	6	40	4	M5	8	M5	10
665020	HYDRO-FIX SP-12/20-100	12	20	100	9.5	4.75	6	40	4	M5	16	M5	10
665090	HYDRO-FIX SP-12/22-75***	12	22	75	10.5	4.75	6	40	4	M5	8	M5	10
665030	HYDRO-FIX SP-12/22-100	12	22	100	10.5	4.75	6	40	4	M5	16	M5	10
665040	HYDRO-FIX SP-12/25-100	12	25	100	12	4.75	6	40	4	M5	16	M5	10
665050	HYDRO-FIX SP-12/1"-100	12	25.4	100	12.2	4.75	6	40	4	M5	16	M5	10
665060	HYDRO-FIX SP-20/32-100	20	32	100	15.5	8.5	7	52	4	M8	25	M8	10

*) No center thread or coolant connetion.

**) Only one flat surface.

Application area

Machine Mfg.	Machine type	665000	665010 665070	665020 665080	665030 665090	665040	665050	665060
CITIZEN	C		•				•	
	L20		•					
	L32						•	
	M						•	
	M16		•					
STAR	12 SERIES				•			
	20 SERIES				•			
NOMURA	NN-20 SERIES				•			
	NN-3X	•						
NEXTURN*	-		•			•		
TSUGAMI	20			•				
	B012			•				
	S20			•				
	32 SERIES					•		
HANWHA	SL 12H			•				
	20 SERIES					•		
	XD 38II							•
TORNOS	DELTA 20				•			
	GAMMA 20			•	•			
	DECO (7/19/13/20)					•		
	NANO	•						

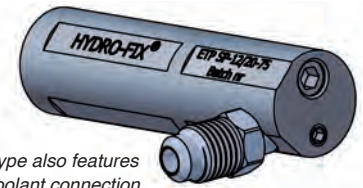

***) This type also features a radial coolant connection.



* depending on machine type

Information:

*) Tool/toolbar shank h6 or h7 can be used.
 **) Recommended tolerance of toolholder bore - H7.
 Adjustment screw included in shipment.
 Can also be ordered separately as spare part.
 M5x0.8-16 Part no. S041



Accessories:

Use preset Torque Wrench to ensure correct mounting of tools.
 6 Nm - Part no. 19055



ETP HYDRO-FIX can be used with reduction sleeves.
 For additional information see section Accessories.



Adaptors:

Male M8x1.25 to Male 1/4" JIC Part no. 19152
 Male M5 to Male 1/4" JIC Part no. 19153



ETP HYDRO-FIX SBW®

Hydraulic **Swiss Back-Working** precision clamping holders

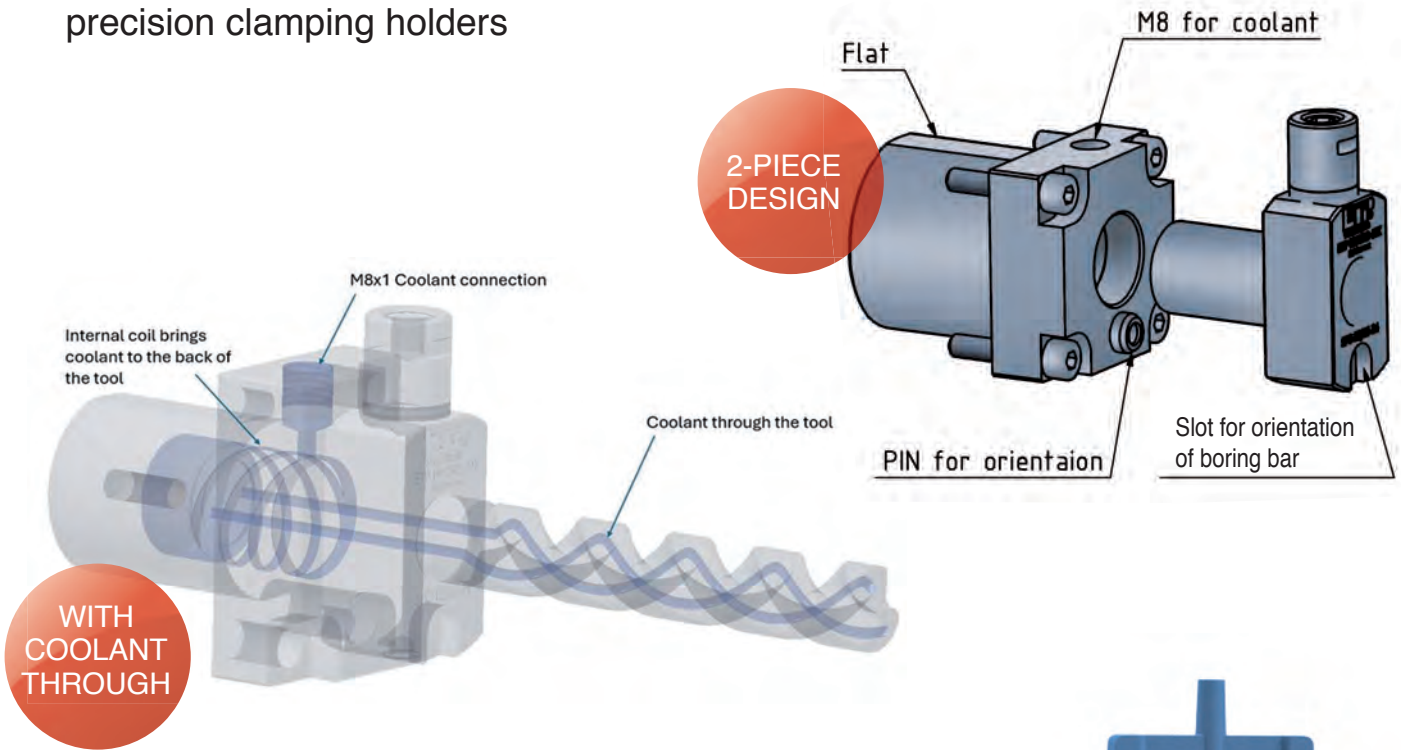

ETP SWISS backworking application

- 1 . FIND YOUR MACHINE
- 2 . CHOOSE SUITABLE ETP HYDRO-FIX HOLDER
- 3 . CHOOSE YOUR ACCESSORIES

THREE EASY STEPS!



1. MACHINE		2. CHOOSE ETP HYDRO-FIX HOLDER						
Machine Mfg.	Machine type	670010	670020	670030	670040	670050	670060	670070
STAR	SB20	•	•					
	SR20	•	•					
	SR20J	•	•					
	SR32J	•	•					
	SR32JII	•	•					
	SR38	•	•					
	SV-38R			•				
CITIZEN	SX38			•				
	L12				•			
	L20					•		
MAZAK	L32X						•	•
	SYNCREX 20/8			•				
	SYNCREX 25/8			•				
	SYNCREX 38/8			•				

Additional information:

Tool/toolbar shank h6 or h7 can be used. Adjustment screw included in shipment. Can also be ordered separately as spare part. M5x0.8-16 Part no. S041 or M8x1.25-25 Part no. S057



Accessories:

Use a preset torque wrench to ensure correct mounting of tools. 6 Nm - Part no. 19055



50mm long bit for wrench Part no. ETP-630



ETP HYDRO-FIX can be used with reduction sleeves.

- R1912.****
- R1920.****
- R1925.****



Extractors available for all sleeves
E7321.12000 - 12mm
E7321.20000 - 20mm
E7321.25000 - 25mm

Coolant adaptors:

Male M8x1.25 to Male 1/4" JIC Part no. 19152



Orientation kit

For quick and easy tool setting, see page 17-18.



670010 - ETP HYDRO-FIX SBW-12/22-25 F1

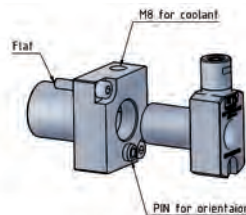
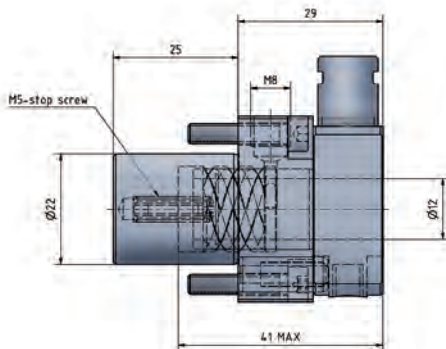
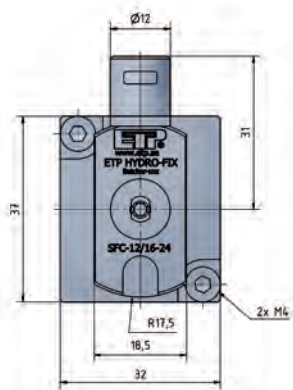

Machine type

- SB20
- SR20
- SR20J
- SR32J
- SR32JII
- SR38



670020 - ETP HYDRO-FIX SBW-12/22-25 F2

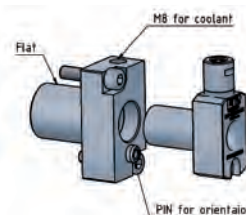
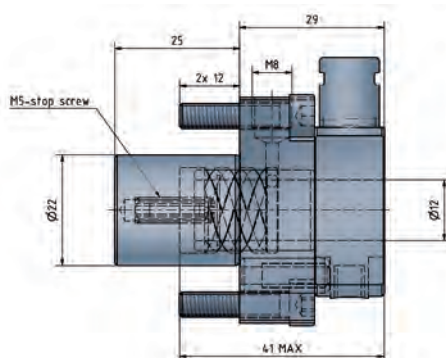
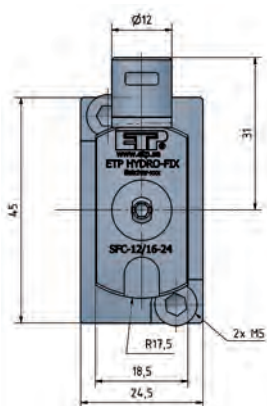

Machine type

- SB20
- SR20
- SR20J
- SR32J
- SR32JII
- SR38



670030 - ETP HYDRO-FIX SBW-12/34-30 F1

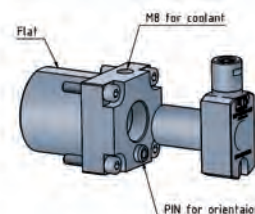
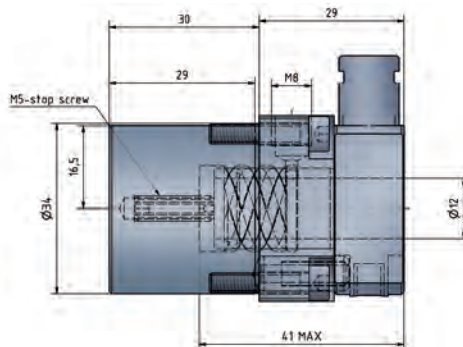
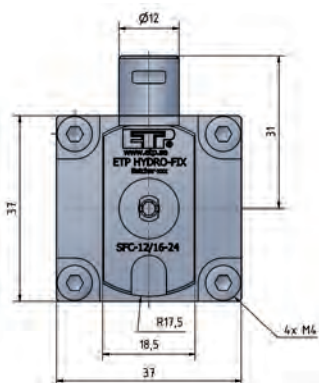

Machine type

Machine type

- SV-38R
- SX38



- SYNCREX 20/8
- SYNCREX 25/8
- SYNCREX 38/8



670040 - ETP HYDRO-FIX SBW-12/25-33 F1

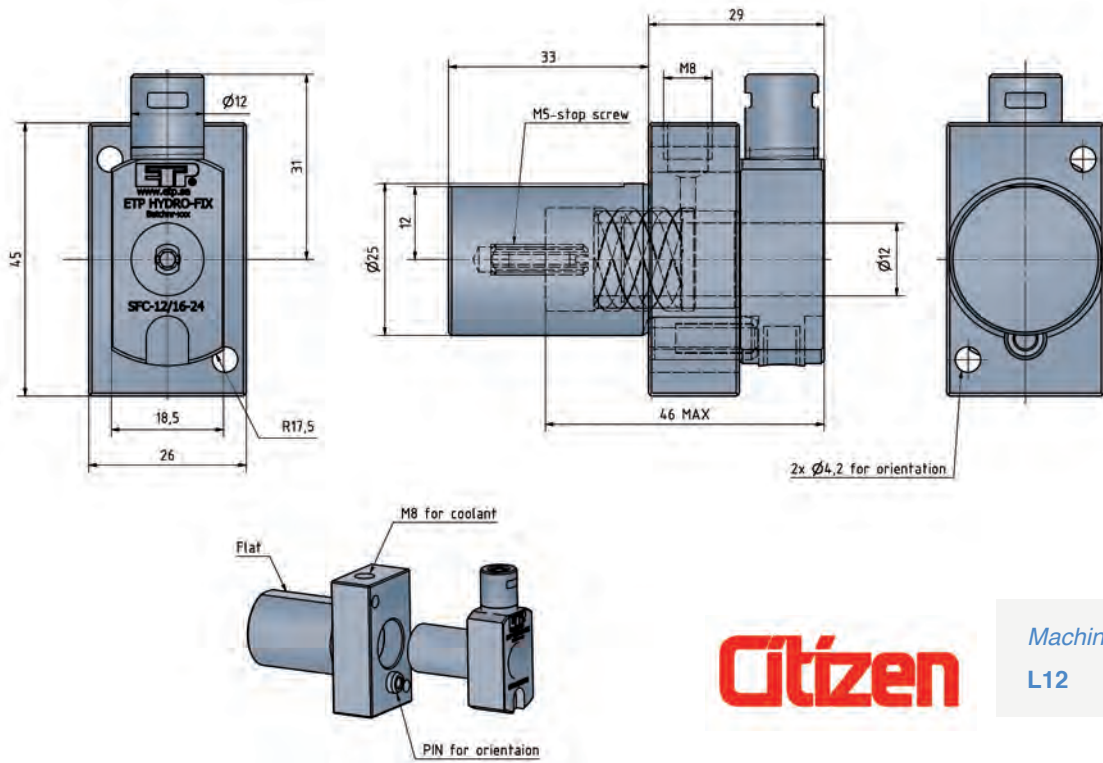

Machine type
L12

670050 - ETP HYDRO-FIX SBW-12/25-30 F1

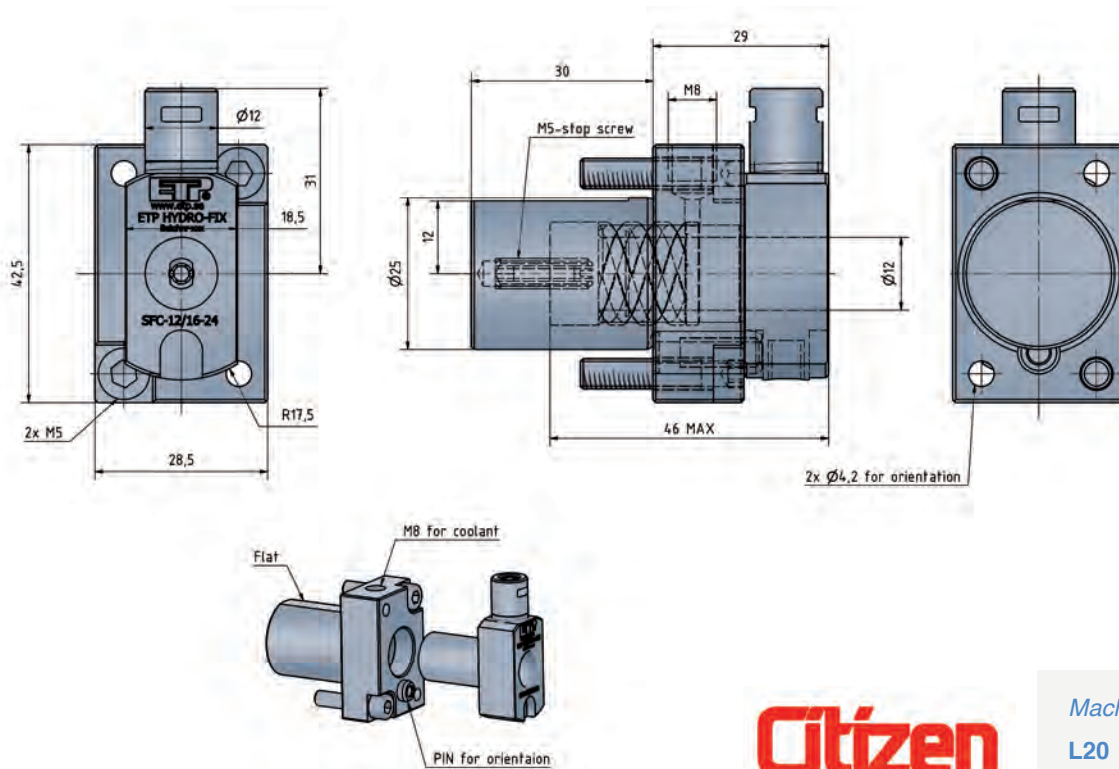

Machine type
L20

670060 - ETP HYDRO-FIX SBW-12/31-36 F1

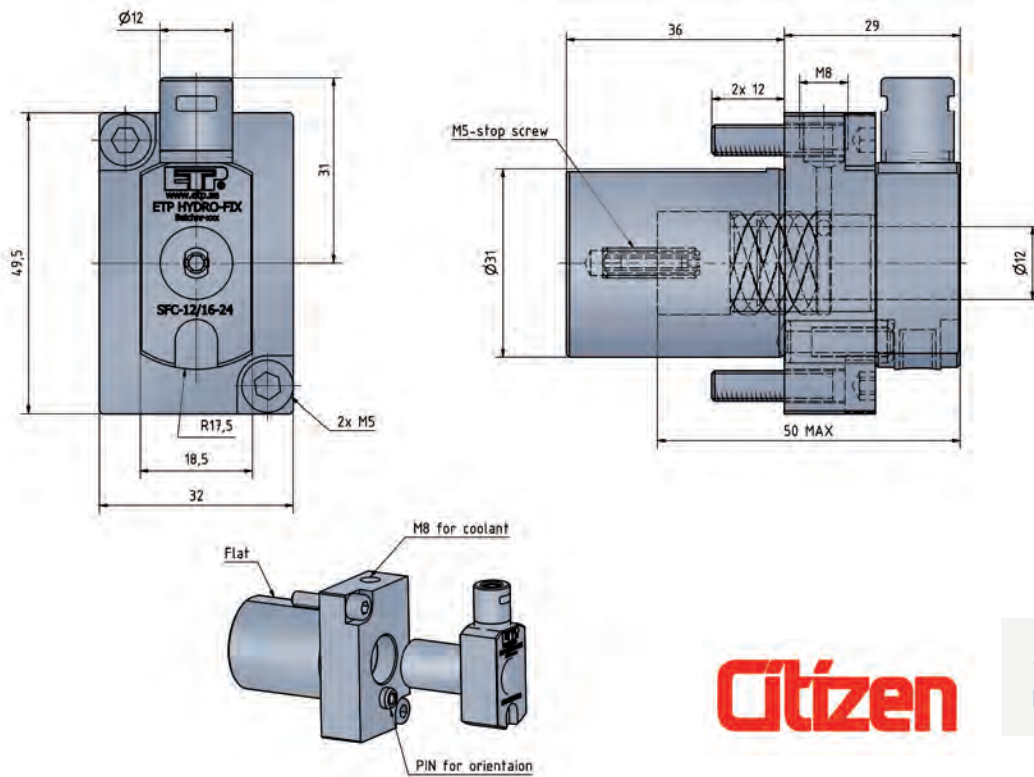

Citizen

Machine type
L32X

670070 - ETP HYDRO-FIX SBW-20/31-36 F1

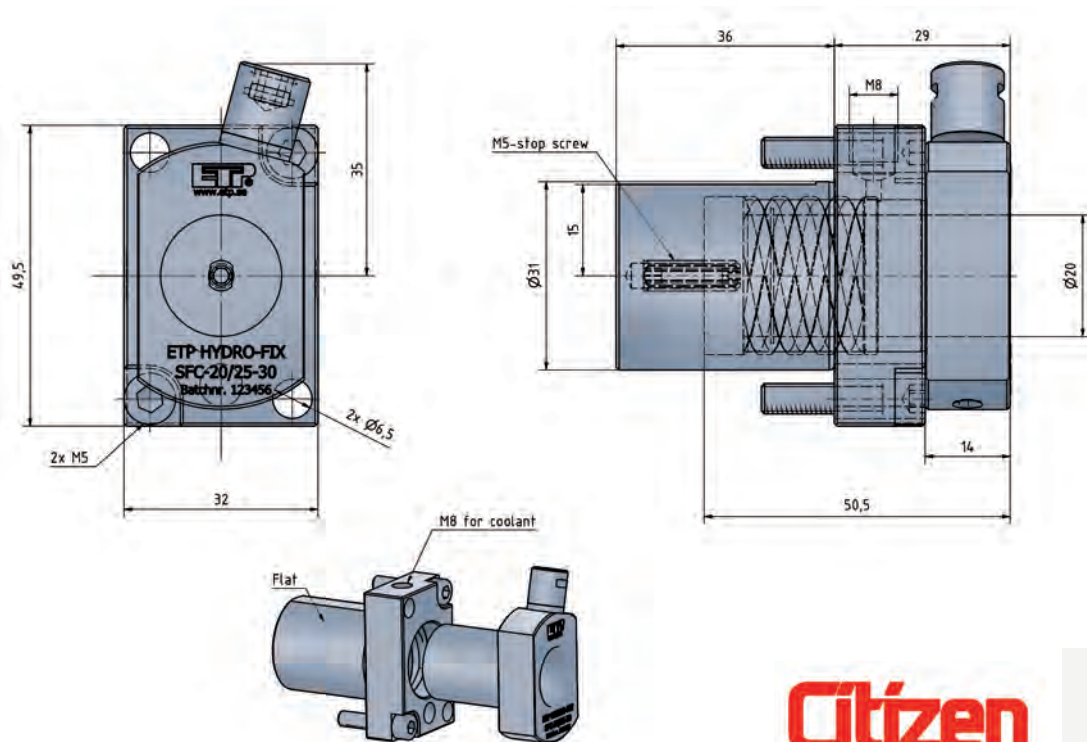

Citizen

Machine type
L32X

Accessories ETP HYDRO-FIX Orientation kit

EASY
TOOL
SETTING



BENEFITS & FEATURES

- Quick and Easy tool setting
- Less down-time
- Fits tools from 4 - 12 mm
- Pre-set your tools outside of machine
- Can be used for both round bars as well as Easy-Fix bars

Quick and Easy tool setting with our Orientation kit!

With our new ETP HYDRO-FIX orientation kit you can now enjoy quick and easy tool setups even outside of your machine.

With our external orientation fixture

and the accompanying orientation discs, that come in all sizes ranging from 4 - 12 mm, allow you now to pre-set any tools and keep ready for installment. Both standard round tool

bars as well as Easy-Fix tool bars can be used!

Start now and reduce your downtime!

Accessories ETP HYDRO-FIX Orientation kit



This orientation kit allows you to easily and with precision set your tool bar outside of the machine and transfer the settings to your installed ETP HYDRO-FIX clamping holder.



Part no.	Description
664180	ETP HYDRO-FIX Orientation kit
	Fixture Ø 12 mm. Incl. Stop plug with set screw
	Orientation discs
	Orientation disc Ø 4 mm. Orientation disc Ø 6 mm. Orientation disc Ø 8 mm. Orientation disc Ø 12 mm.
	Reduction sleeves
	HS 12 / 4 mm. HS 12 / 6 mm. HS 12 / 8 mm.
	Wrenches & Accessories
	Torque wrench 0.45 Nm (2.5 mm Hex) Allen key (1.5 mm) Screw M3x8

Accessories/Spare parts

Part no.	Description
664180-4	Orientation disc Ø 4 mm.
664180-5	Orientation disc Ø 5 mm.
664180-6	Orientation disc Ø 6 mm.
664180-7	Orientation disc Ø 7 mm.
664180-8	Orientation disc Ø 8 mm.
664180-10	Orientation disc Ø 10 mm.
664180-12	Orientation disc Ø 12 mm.

View video instructions

Scan the codes to see the complete procedure on how to use your ETP HYDRO-FIX orientation kit!

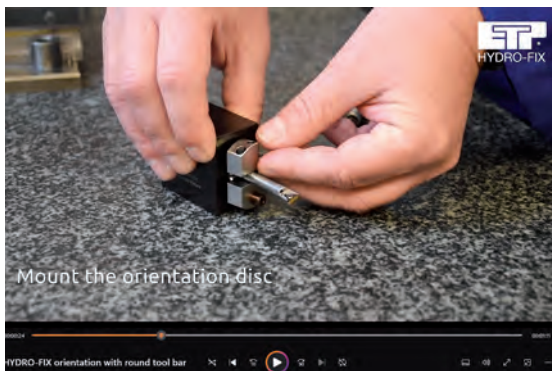

Using round bars



Using Easy-Fix bars



ETP HYDRO-FIX®

Hydraulic high precision clamping sleeve



New Generation

ETP HYDRO-FIX clamping sleeves are excellent for boring bars for internal and external turning as well as in driven toolholders. With the one screw fix system it is quick and easy to handle.

The clamping is uniform around the tool and therefore the tool life is improved. The clamping system absorbs and reduces vibration, improves surface quality and best of all increases your productivity!

BENEFITS & FEATURES

- Reduced vibrations
- Increased speed and/or feed
- Improved surface quality
- Increased tool life
- Quick and easy handling
- Increased overhang possible
- Safe clamping of solid carbide tools. No risk of damages

ETP HYDRO-FIX®

For Driven tools & Static Boring bars

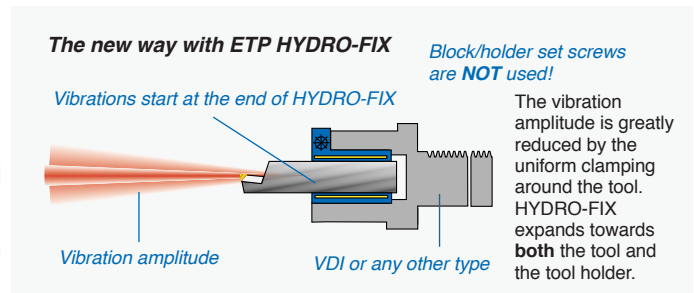
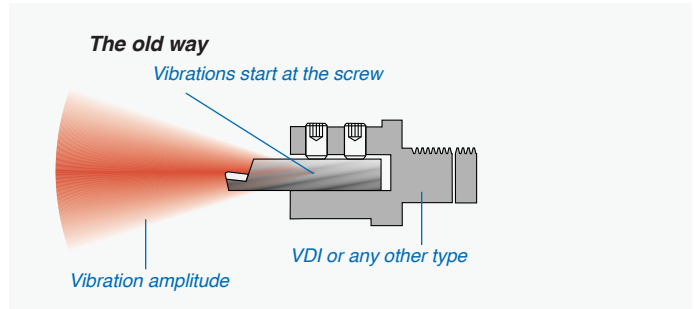
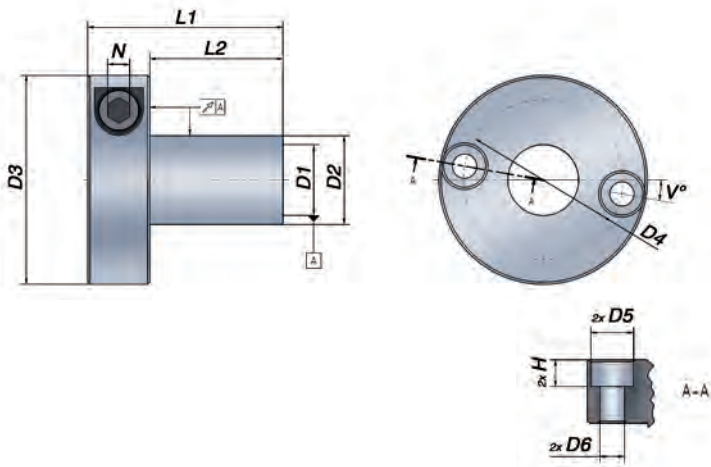

Metric range

Technical Specification

Part no.	Item description	Dimensions, mm					Recommended screws DIN 915, 12.9					Pressure screw		Runout mm	T* Nm	Weight kg
		D1*	D2**	D3	L1	L2	D4	D5	D6	H	V°	N	Tt*** Nm			
851215	HYDRO-FIX 12/16-38	12	16	43.5	38	24	28	9.5	5.5	6	5	5	6	0.006	60	0.15
851615	HYDRO-FIX 16/20-44	16	20	47	44	30	36	9.5	5.5	6	10	5	6	0.006	165	0.17
852015	HYDRO-FIX 20/25-44	20	25	52	44	30	36	11	6.5	7		5	6	0.006	260	0.21
852515	HYDRO-FIX 25/32-48	25	32	59	48	34	44	11	6.5	7		5	6	0.010	350	0.30
853215	HYDRO-FIX 32/40-53	32	40	69.5	53	39	52	11	6.5	7		5	6	0.010	630	0.43
854015	HYDRO-FIX 40/50-69	40	50	79	69	55						5	6	0.015	320	0.96
854215	HYDRO-FIX 42/50-76	42	50	89	76	56						8	10	0.015	800	0.94
855015	HYDRO-FIX 50/60-80	50	60	98.5	80	60						8	10	0.015	800	1.23
856015	HYDRO-FIX 60/80-90	60	80	115.5	90	70						8	10	0.015	800	2.34

Inch range

Technical Specification

Part no.	Item description	Dimensions, inch					Recommended screws DIN 915, 12.9					Pressure screw		Runout inch	T* ft-lb	Weight kg
		D1*	D2**	D3	L1	L2	D4	D5	D6	H	V°	N	Tt*** Nm			
851315	HYDRO-FIX 1/2"/5/8"-38	0.500	0.625	1.713	1.496	0.945	1.102	0.374	0.217	0.236	5	0.197	6	0.00024	44	0.15
851515	HYDRO-FIX 5/8"/3/4"-44	0.625	0.750	1.850	1.732	1.181	1.417	0.374	0.217	0.236	10	0.197	6	0.00024	121	0.17
851915	HYDRO-FIX 3/4"/1"-44	0.750	1.000	2.047	1.732	1.181	1.417	0.433	0.256	0.276		0.197	6	0.00039	191	0.21
852615	HYDRO-FIX 1"/1 1/4"-48	1.000	1.250	2.323	1.890	1.339	1.732	0.433	0.256	0.276		0.197	6	0.00039	258	0.30
853125	HYDRO-FIX 32/1 1/2"-53	1.260	1.500	2.736	2.087	1.535	2.047	0.433	0.256	0.276		0.197	6	0.00039	465	0.43
853115	HYDRO-FIX 1 1/4"/1 1/2"-53	1.250	1.500	2.736	2.087	1.535	2.047	0.433	0.256	0.276		0.197	6	0.00039	465	0.43
853351	HYDRO-FIX-1 1/4"/2"-60	1.250	2.000	3.110	2.362	1.811						0.197	6	0.00039	465	0.90
853915	HYDRO-FIX 1 1/2"/2"-69	1.500	2.000	3.110	2.717	2.165						0.197	6	0.00059	118	1.06
855115	HYDRO-FIX 2"/2 1/2"-80	2.000	2.500	3.996	3.150	2.362						0.315	10	0.00059	590	1.42
856315	HYDRO-FIX 2 1/2"/3"-93	2.500	3.000	4.685	3.661	2.874						0.315	10	0.00059	885	1.98

***) T_t = Recommended tightening torque for the screw in Nm! Further tightening does not increase the pressure.

*) T = Transmittable torque using a h6 cylindrical tool, full depth (L1) insert.

For dimensions 12 mm (1/2") - 20 mm (3/4"):

When using a non-cylindrical tool/toolbar - we recommend the use of a reduction sleeve to avoid plastic deformation of ETP HYDRO-FIX.

Information:

*) Tool/toolbar shank h6 or h7 can be used.

***) Recommended tolerance of toolholder bore - H7.

Balanced by design. For use above

3 000 rpm - we recommend individual balancing.

Accessories:

Use preset Torque Wrench to ensure correct mounting of tools.

6 Nm - Part no. 19050

10 Nm - Part no. 19054



Digital Spirit Level

For easy toolbar alignment use the ETP Digital Spirit Level *
Part no. 885010



*) 3x CR2032 battery - not included.

ETP ER PLUG & PLAY

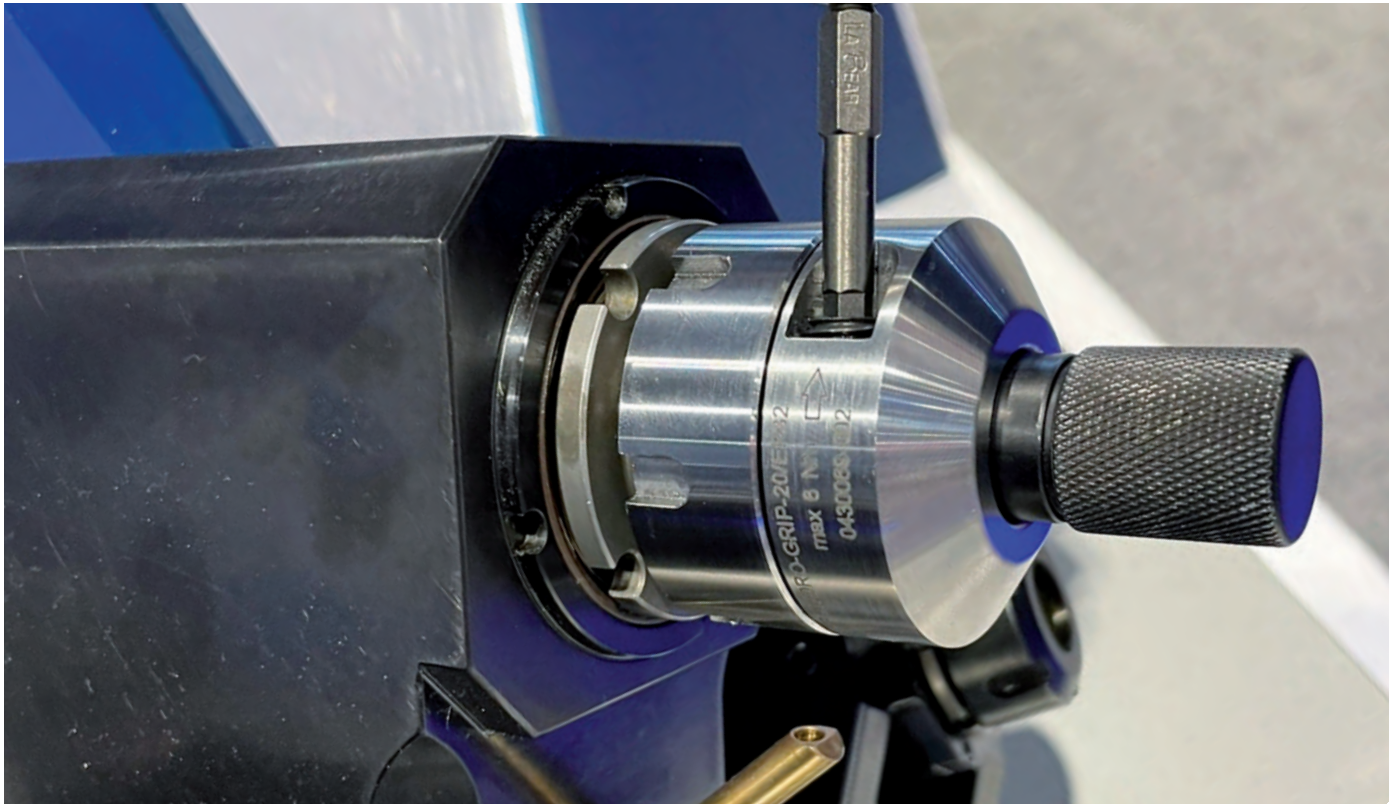

Turn your lathe live ER chucks into quick change hydraulic chucks

With ETP ER you can easily turn your standard ER collet driven tools into high precision hydraulic holders. Thus you can easily enjoy all the positive benefits of hydraulic clamping such as easy handling and precision, at an impressive

competitive price level. This enables more users to benefit from decrease tool wear and increased productivity, when compared to using ER collet holders. Simply put it, just **Plug & Play!**



BENEFITS & FEATURES

- Turn ER driven tools into hydraulic
- Easy handling and precision
- Excellent repeatability



NO MORE:

- Time-consuming tool changes
- Runout issues
- Limited clamping force

ETP ER PLUG & PLAY

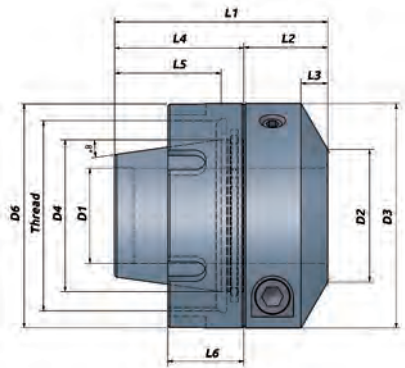

Design 1

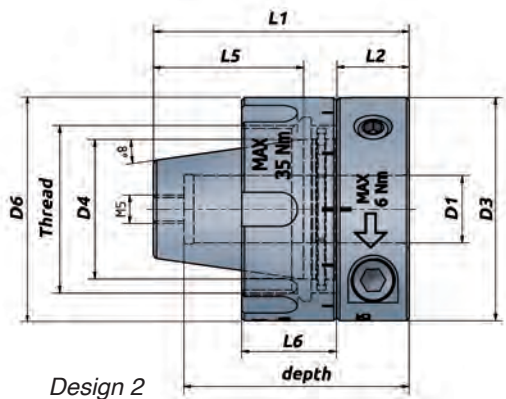

Design 2

Simple mounting procedure

1. Mount the ETP ER in the output shaft and twist to seal
2. Tighten the thread nut to the recommended tightening torque



View video instruction

Scan the code to see the complete procedure how to mount your ETP ER holder!

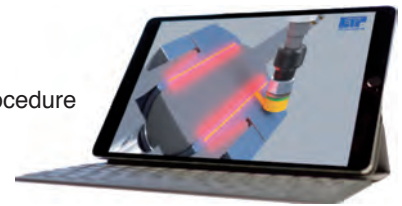

Metric range

Technical Specification

Design	ER Size	Part no.	Description	Dimensions, mm											Internal thread nut		Transmittable torque	Features		Use Torque wrench		
				D1	D2	D3	D4	L1	L2	L3	L4	L5	depth	D6	L6	Thread	Tt**	T* Nm	Max.Runout Nm	Backstop mm	Part no.	Tt***
1	16	671115	HYDRO-FIX-6/ER16	6	-	25	16	30	8	-	-	16	27.5	28	12	M22x1,5	25	12-22	0.01	Yes	19070	2
1	16	671116	HYDRO-FIX-6/ERM16	6	-	25	16	30	8	-	-	16	27.5	25	12	M19x1	25	12-22	0.01	Yes	19070	2
1	20	671125	HYDRO-FIX-6/ER20	6	-	28	20	36	9	-	-	21	27.5	30	12	M25x1,5	30	12-22	0.01	Yes	19070	2
1	20	671126	HYDRO-FIX-6/ERM20	6	-	28	20	36	9	-	-	21	27.5	28	12	M24x1	30	12-22	0.01	Yes	19070	2
1	25	671135	HYDRO-FIX-12/ER25	12	-	40	25	46	13	-	-	27	40.5	42	17	M32x1,5	35	60-125	0.01	Yes	19055	6
1	25	671136	HYDRO-FIX-12/ERM25	12	-	40	25	46	13	-	-	27	40.5	40	17	M30x1	35	60-125	0.01	Yes	19055	6
2	25	671130	HYDRO-GRIP-12/ER25	12	26	48	25	46	22	7	24	18	-	48	17	M32x1,5	35	50-90	0.02	No	19050	6
2	32	671150	HYDRO-GRIP-20/ER32	20	30	52	32	52	21.5	7	30.5	24.5	-	52	19	M40x1,5	40	230-370	0.02	No	19050	6
2	40	671160	HYDRO-GRIP-25/ER40	25	35	59	40	56	22	7	34	28	-	59	20	M50x1,5	50	420-600	0.02	No	19050	6

Inch range

Technical Specification

Design	ER Size	Part no.	Description	Dimensions, inch											Internal thread nut		Transmittable torque	Features		Use Torque wrench		
				D1	D2	D3	D4	L1	L2	L3	L4	L5	depth	D6	L6	Thread	Tt**	T* Nm	Max.Runout Nm	Backstop mm	Part no.	Tt***
2	25	671230	HYDRO-GRIP-1/2"/ER25	0.500	1.024	1.575	0.984	1.811	0.512	0.276	1.063	1.063	-	1.890	0.669	M32x1.5	35	37 - 66	0.02	No	19050	6
2	32	671250	HYDRO-GRIP-3/4"/ER32	0.750	1.181	2.047	1.260	2.047	0.846	0.276	1.201	1.201	-	2.047	0.748	M40x1.5	40	170 - 273	0.02	No	19050	6
2	40	671260	HYDRO-GRIP-1"/ER40	1.000	1.378	2.323	1.575	2.205	0.866	0.276	1.339	1.339	-	2.323	0.787	M50x1.5	50	310 - 443	0.02	No	19050	6

*) T = Min. and Max transmittable torque using a h6 cylindrical tool, full depth insert.

**) Tt = Recommended tightening torque of the thread nut.

***) Tt = Recommended tightening torque of the pressure screw.

Information:

- Tool shank h6 or h7 can be used.
- Balanced by design. Max. 25 000 rpm.

Accessories:

Use preset torque wrench to ensure correct mounting of tools. See table above for Part no.

ETP ER can be used with reducing sleeves.



ETP ECOGRIP™ ER

For outer threaded toolholders and driven tools

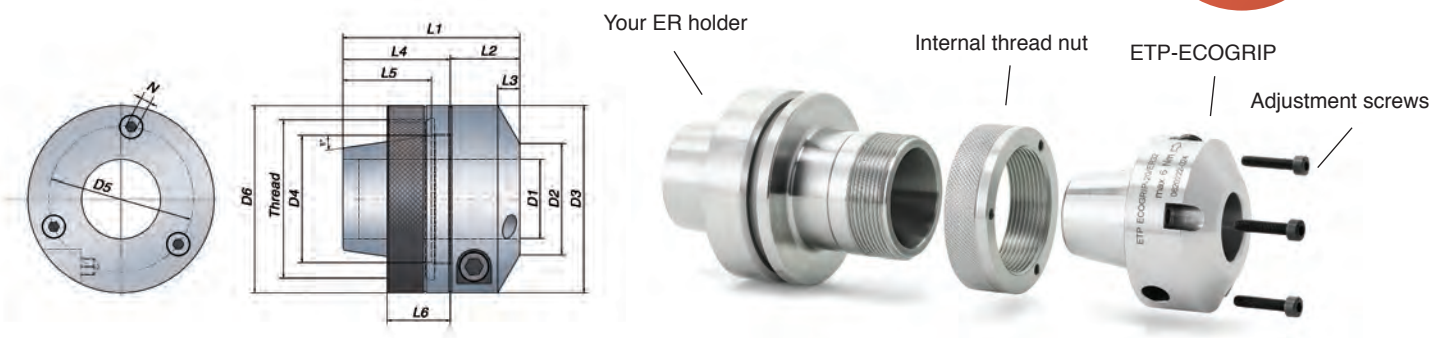

Metric range

Technical Specification																					
ER size	Part no.	Item description	Dimensions, mm										Adjustment screws				Internal thread nut			T* Nm	
			D1	D2	D3	D4	L1	L2	L3	L4	L5	D5	No.	Dim.	N	D6	L6	Thread			
16	686845	ECOGRIP-6/ER16	6	16	34	16	30	14	5	16	14	28	2	M3x16*	2.5	34	10	M22x1.5	6-14		
	686846	ECOGRIP-6/ERM16	6	16	34	16	30	14	5	16	14	28	2	M3x16*	2.5	34	10	M19x1	6-14		
	704952	ECOGRIP-8/ER16	8	18	36	16	30	14	5	16	14	28	2	M3x16*	2.5	36	10	M22x1.5	14 - 35		
	705718	ECOGRIP-8/ERM16	8	18	36	16	30	14	5	16	14	28	2	M3x16*	2.5	34	10	M19x1	14 - 35		
20	686855	ECOGRIP-12/ER20	12	22	43.5	20	40	24	7	16	14	34	3	M4x20	3	43.5	12	M25x1.5	50-90		
	686856	ECOGRIP-12/ERM20	12	22	43.5	20	40	24	7	16	14	34	3	M4x20	3	43.5	12	M24x1	50-90		
25	686905	ECOGRIP-12/ER25	12	26	48	25	46	26	7	20	18	41	3	M4x20	3	48	13	M32x1.5	50-90		
	686906	ECOGRIP-12/ERM25	12	26	48	25	46	26	7	20	18	41	3	M4x20	3	48	13	M30x1	50-90		
	686875	ECOGRIP-16/ER25	16	26	48	25	46	26	7	20	18	41	3	M4x20	3	48	13	M32x1.5	120-200		
	686876	ECOGRIP-16/ERM25	16	26	48	25	46	26	7	20	18	41	3	M4x20	3	48	13	M30x1	120-200		
32	686865	ECOGRIP-20/ER32	20	30	52	32	52	25.5	7	26.5	24.5	45	3	M4x20	3	52	15	M40x1.5	230-370		
40	686885	ECOGRIP-25/ER40	25	35	59	40	56	22	7	34	28	46	3	M4x16	3	59	20	M50x1.5	420-600		
50	686895	ECOGRIP-32/ER50**	32	42	69.5	50	60	22	7	38	32	56	3	M4x15	3	78	20	M64x2	660-1000		

Inch range

Technical Specification																					
ER size	Part no.	Item description	Dimensions, inch										Adjustment screws				Internal thread nut			T* ft-lb	
			D1	D2	D3	D4	L1	L2	L3	L4	L5	D5	No.	Dim.	N	D6	L6	Thread			
16	686945	ECOGRIP-1/4"/ER16	0.250	0.630	1.339	0.630	1.181	0.551	0.197	0.630	0.551	1.102	2	M3x16*	0.098	1.339	0.394	M22x1.5	4.4-10		
20	686955	ECOGRIP-1/2"/ER20	0.500	0.866	1.713	0.787	1.575	0.945	0.276	0.630	0.551	1.339	3	M4x20	0.118	1.713	0.472	M25x1.5	37-66		
	686956	ECOGRIP-1/2"/ERM20	0.500	0.866	1.713	0.787	1.575	0.945	0.276	0.630	0.551	1.339	3	M4x20	0.118	1.713	0.472	M24x1	37-66		
25	687005	ECOGRIP-1/2"/ER25	0.500	1.024	1.890	0.984	1.811	1.024	0.276	0.787	0.709	1.614	3	M4x20	0.118	1.890	0.512	M32x1.5	37-66		
	686975	ECOGRIP-5/8"/ER25	0.625	1.024	1.890	0.984	1.811	1.024	0.276	0.787	0.709	1.614	3	M4x20	0.118	1.890	0.512	M32x1.5	89-148		
32	686965	ECOGRIP-3/4"/ER32	0.750	1.181	2.047	1.260	2.047	1.004	0.276	1.043	0.965	1.772	3	M4x20	0.118	2.047	0.591	M40x1.5	170-273		
40	686985	ECOGRIP-1"/ER40	1.000	1.378	2.323	1.575	2.205	0.866	0.276	1.339	1.102	1.811	3	M4x16	0.118	2.323	0.787	M50x1.5	310-443		
50	686995	ECOGRIP-1 1/4"/ER50**	1.250	1.654	2.736	1.969	2.362	0.866	0.276	1.496	1.260	2.205	3	M4x15	0.118	3.071	0.787	M64x2	487-738		

*) This size ECOGRIP ER has 2x M3x16 adjustment screws located 180 degrees apart. It also has an additional 2x M5x8 adjustment screws, located 180 degrees apart, at the back of the thread nut.

**) The thread nut width L6 of this size ECOGRIP ER is 20 mm. The thread depth is however only 15 mm.

*) T = Min. and Max transmittable torque using a h6 cylindrical tool, full depth insert. For additional information see section Technical Information.

Information:

- Runout accuracy - adjustable!
- When mounted correctly, an initial runout of approx. 0.020 mm is achieved. Adjust runout further by lightly tightening on the adjustment screws until your desired runout is achieved.
- Tool shank h6 or h7 can be used
- Balanced by design. For use above 5 - 10 000 rpm – we recommend individual balancing.

Accessories:

Use preset Torque Wrench, 6 Nm, to ensure correct mounting of tools. Part no. 19050. For ER16 Use Torque wrench Part no. 19055.

ETP ECOGRIP ER can be used with reducing sleeves. For additional information see section Accessories.



ETP ECOGRIP™ ER

For inner threaded driven tools

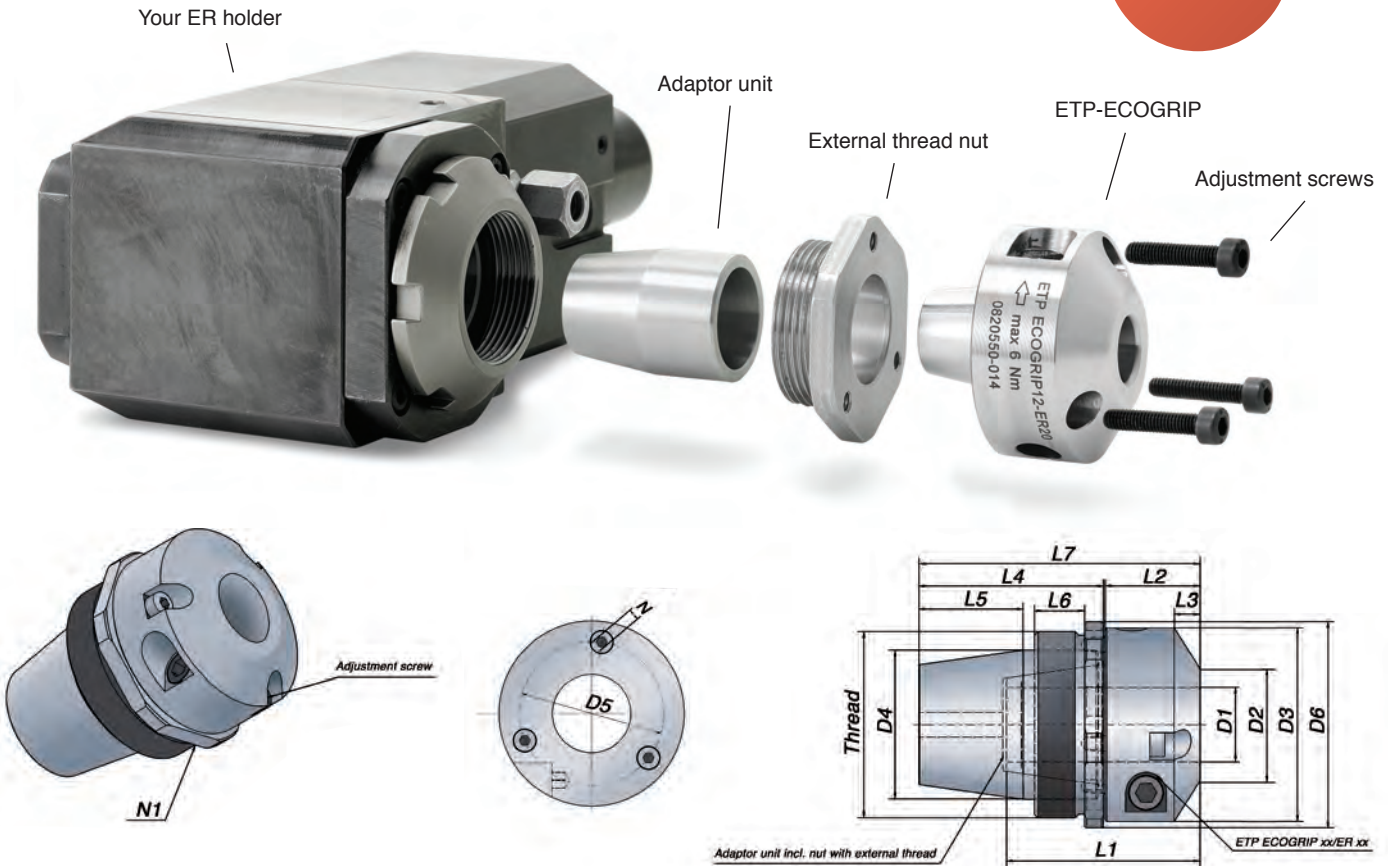

Metric range

Technical Specification

ER size	Part no.	Item description	Dimensions, mm											Adjustment screws				External thread nut				
			D1	D2	D3	D4	L1	L2	L3	L4	L5	L7	D5	No.	Dim.	N	D6	L6	Thread	N1	Tt Nm	T* Nm
25	687310	ECOGRIP-12/ER20-25	12	22	43.5	25	40	24	7	36	18	60.5	34	3	M4x16	3	43.5	10	M32x1.5	40	50	50-90
32	687320	ECOGRIP-12/ER25-32	12	26	48	32	46	26	7	44.5	24.5	71	41	3	M4x16	3	48	12	M40x1.5	44	104	50-90
	687330	ECOGRIP-16/ER25-32	16	26	48	32	46	26	7	44.5	24.5	71	41	3	M4x16	3	48	12	M40x1.5	44	104	120-200
40	687340	ECOGRIP-20/ER32-40	20	30	52	40	52	25.5	7	49.5	28	75.5	45	3	M4x16	3	56	13.5	M50x1.5	52	128	230-370

Inch range

Technical Specification

ER size	Part no.	Item description	Dimensions, inch											Adjustment screws				External thread nut				
			D1	D2	D3	D4	L1	L2	L3	L4	L5	L7	D5	No.	Dim.	N	D6	L6	Thread	N1	Tt Nm	T* ft-lb
25	687410	ECOGRIP-1/2"/ER20-25	0.500	0.866	1.713	0.984	1.575	0.945	0.276	1.417	0.709	2.382	1.339	3	M4x16	0.118	1.713	0.394	M32x1.5	1.575	50	37-66
32	687420	ECOGRIP-1/2"/ER25-32	0.500	1.024	1.890	1.260	1.811	1.024	0.276	1.752	0.965	2.795	1.614	3	M4x16	0.118	1.890	0.472	M40x1.5	1.732	104	37-66
	687430	ECOGRIP-5/8"/ER25-32	0.625	1.024	1.890	1.260	1.811	1.024	0.276	1.752	0.965	2.795	1.614	3	M4x16	0.118	1.890	0.472	M40x1.5	1.732	104	89-148
40	687440	ECOGRIP-3/4"/ER32-40	0.750	1.181	2.047	1.575	2.047	1.004	0.276	1.949	1.102	2.972	1.772	3	M4x16	0.118	2.205	0.531	M50x1.5	2.047	128	170-273

Tt: Recommended tightening torque in Nm for the External thread nut.

*) T = Min. and Max transmittable torque using a h6 cylindrical tool, full depth insert. For additional information see section Technical Information.

Direct shank - Full insertion required.

Information:

- Runout accuracy - adjustable!
When mounted correctly, an initial runout of approx. 0.020 mm is achieved. Adjust runout further by lightly tightening on the adjustment screws until your desired runout is achieved.
- Tool shank h6 or h7 can be used
- Balanced by design

Accessories:

Use preset Torque Wrench, 6 Nm, to ensure correct mounting of tools. Part no. 19050.

ETP ECOGRIP ER can be used with reducing sleeves.

When using reduction sleeves:

- ER16/ER20 an M3 plug can be used for a solid backstop
- ER25 an M5 adjustment screw can be used for a backstop



Reduction Sleeves for ETP Clamping holders



Reduction sleeve HS - for internal cooling

The reduction sleeves are designed to fit with the ETP clamping holders. They are specially suited for high precision clamping of cylindrical tool shanks per DIN 6335 form HA, HB and HE, as well as tool shanks per DIN 1835 form B, C, D and E.

The special design of the reduction sleeves allows an efficient use of coolant through cutting tools.

Reduction sleeve HS-CF - for peripheral cooling.

Outer-Ø of reduction sleeve corresponds to the type.

- HS12 = Ø 12 mm
- HS20 = Ø 20 mm
- HS25 = Ø 25 mm
- HS32 = Ø 32 mm

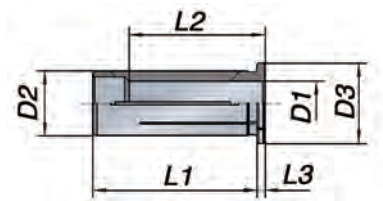

BENEFITS & FEATURES

- **Standard version HS suited for internal cooling**
Metal-to-metal seal for cutting tools with internal coolant channels.
- **HS-CF version suited for peripheral cooling**
The coolant flush reduction sleeves HS-CF can be used for peripheral cooling due to their coolant channels.
- **Accurate precision**
High runout accuracy < 3 µm.
- **High flexibility**
Clamping of different tool shank diameters. 12, 20, 25, 32 mm and 1/2", 3/4", 1", 1 1/4".
- **Power increase**
When using reduction sleeves the transmittable torque is increased.

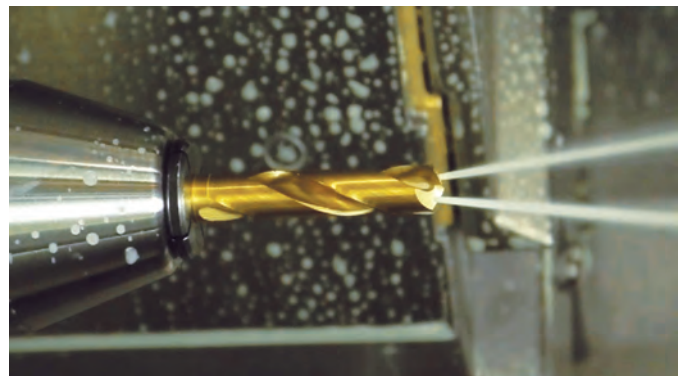

Using Reduction sleeve HS - for internal cooling.

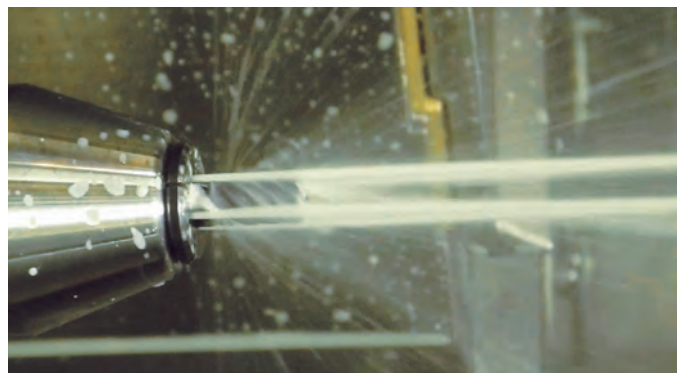

Using Reduction sleeve HS-CF - for peripheral cooling.

Reduction Sleeves mm to mm

Reduction Sleeves mm to mm								
Part no.	Item description	D2 mm	D1 mm	D3 mm	L1 mm	L2 mm	L3 mm	Min. tool insert depth*
Reduction Sleeves HS 6								
R1906.01000	HS 6 / 1 mm	6	1	9	27	20	3	15.5
R1906.02000	HS 6 / 2 mm	6	2	9	27	24	3	21
R1906.03000	HS 6 / 3 mm	6	3	9	27	30	3	26
R1906.04000	HS 6 / 4 mm	6	4	9	27	30	3	26
Reduction Sleeves HS 8								
R1908.06000	HS 8 / 6 mm	8	6	11	27	30	3	26
Reduction Sleeves HS 12-MB (Micro Bore) <i>MB can not seal for coolant through tools.</i>								
R1912.01009	HS 12-MB / 1 mm	12	1.000	16	40	20	4	44
R1912.01509	HS 12-MB / 1,5 mm	12	1.500	16	40	20	4	44
R1912.02009	HS 12-MB / 2 mm	12	2.000	16	40	20	4	44
R1912.02509	HS 12-MB / 2,5 mm	12	2.500	16	40	20	4	44
Reduction Sleeves HS 12								
R1912.03000	HS 12 / 3 mm	12	3.000	16	40	29	4	25
R1912.04000	HS 12 / 4 mm	12	4.000	16	40	29	4	27
R1912.05000	HS 12 / 5 mm	12	5.000	16	40	30	4	28
R1912.06000	HS 12 / 6 mm	12	6.000	16	40	36	4	34
R1912.07000	HS 12 / 7 mm	12	7.000	16	40	37	4	34
R1912.08000	HS 12 / 8 mm	12	8.000	16	40	37	4	34
R1912.09000	HS 12 / 9 mm	12	9.000	16	40	37	4	34
R1912.10000	HS 12 / 10 mm	12	10.000	16	40	40	4	37
Reduction Sleeves HS 12-CF								
R1912.03002	HS 12-CF / 3 mm	12	3.000	16	40	29	4	25
R1912.04002	HS 12-CF / 4 mm	12	4.000	16	40	29	4	27
R1912.05002	HS 12-CF / 5 mm	12	5.000	16	40	30	4	28
R1912.06002	HS 12-CF / 6 mm	12	6.000	16	40	36	4	34
R1912.08002	HS 12-CF / 8 mm	12	8.000	16	40	37	4	34
Reduction Sleeves HS 20								
R1920.03000	HS 20 / 3 mm	20	3.000	25	50	28	4	25
R1920.04000	HS 20 / 4 mm	20	4.000	25	50	28	4	25
R1920.05000	HS 20 / 5 mm	20	5.000	25	50	28	4	25
R1920.06000	HS 20 / 6 mm	20	6.000	25	50	36	4	34
R1920.07000	HS 20 / 7 mm	20	7.000	25	50	38	4	34
R1920.08000	HS 20 / 8 mm	20	8.000	25	50	37	4	35
R1920.09000	HS 20 / 9 mm	20	9.000	25	50	38	4	35
R1920.10000	HS 20 / 10 mm	20	10.000	25	50	40	4	37
R1920.11000	HS 20 / 11 mm	20	11.000	25	50	40	4	37
R1920.12000	HS 20 / 12 mm	20	12.000	25	50	45	4	42
R1920.13000	HS 20 / 13 mm	20	13.000	25	50	45	4	42
R1920.14000	HS 20 / 14 mm	20	14.000	25	50	45	4	42
R1920.15000	HS 20 / 15 mm	20	15.000	25	50	45	4	42
R1920.16000	HS 20 / 16 mm	20	16.000	25	50	48	4	44
R1920.18000	HS 20 / 18 mm	20	18.000	25	50	48	4	46

Reduction Sleeves mm to mm								
Part no.	Item description	D2 mm	D1 mm	D3 mm	L1 mm	L2 mm	L3 mm	Min. tool insert depth*
Reduction Sleeves HS 20-CF								
R1920.03002	HS 20-CF / 3 mm	20	3.000	25	50	28	4	25
R1920.04002	HS 20-CF / 4 mm	20	4.000	25	50	28	4	25
R1920.05002	HS 20-CF / 5 mm	20	5.000	25	50	28	4	25
R1920.06002	HS 20-CF / 6 mm	20	6.000	25	50	36	4	34
R1920.08002	HS 20-CF / 8 mm	20	8.000	25	50	37	4	35
R1920.10002	HS 20-CF / 10 mm	20	10.000	25	50	40	4	37
R1920.12002	HS 20-CF / 12 mm	20	12.000	25	50	45	4	42
R1920.14002	HS 20-CF / 14 mm	20	14.000	25	50	45	4	42
R1920.16002	HS 20-CF / 16 mm	20	16.000	25	50	48	4	44
Reduction Sleeves HS 25								
R1925.03000	HS 25 / 3 mm	25	3.000	30	56	29	4	24
R1925.04000	HS 25 / 4 mm	25	4.000	30	56	29	4	25
R1925.05000	HS 25 / 5 mm	25	5.000	30	56	29	4	27
R1925.06000	HS 25 / 6 mm	25	6.000	30	56	37	4	34
R1925.07000	HS 25 / 7 mm	25	7.000	30	56	37	4	34
R1925.08000	HS 25 / 8 mm	25	8.000	30	56	37	4	34
R1925.09000	HS 25 / 9 mm	25	9.000	30	56	38	4	35
R1925.10000	HS 25 / 10 mm	25	10.000	30	56	40	4	37
R1925.12000	HS 25 / 12 mm	25	12.000	30	56	46	4	41
R1925.14000	HS 25 / 14 mm	25	14.000	30	56	47	4	42
R1925.16000	HS 25 / 16 mm	25	16.000	30	56	48	4	43
R1925.18000	HS 25 / 18 mm	25	18.000	30	56	48	4	44
R1925.20000	HS 25 / 20 mm	25	20.000	30	56	50	4	44
Reduction Sleeves HS 32								
R1932.03000	HS 32 / 3 mm	32	3.000	36	60	29	4	25
R1932.04000	HS 32 / 4 mm	32	4.000	36	60	29	4	26
R1932.05000	HS 32 / 5 mm	32	5.000	36	60	29	4	26
R1932.06000	HS 32 / 6 mm	32	6.000	36	60	36	4	34
R1932.07000	HS 32 / 7 mm	32	7.000	36	60	37	4	34
R1932.08000	HS 32 / 8 mm	32	8.000	36	60	36	4	35
R1932.09000	HS 32 / 9 mm	32	9.000	36	60	37	4	35
R1932.10000	HS 32 / 10 mm	32	10.000	36	60	40	4	36
R1932.11000	HS 32 / 11 mm	32	11.000	36	60	40	4	36
R1932.12000	HS 32 / 12 mm	32	12.000	36	60	45	4	41
R1932.13000	HS 32 / 13 mm	32	13.000	36	60	45	4	41
R1932.14000	HS 32 / 14 mm	32	14.000	36	60	46	4	43
R1932.15000	HS 32 / 15 mm	32	15.000	36	60	46	4	43
R1932.16000	HS 32 / 16 mm	32	16.000	36	60	48	4	44
R1932.17000	HS 32 / 17 mm	32	17.000	36	60	48	4	44
R1932.18000	HS 32 / 18 mm	32	18.000	36	60	49	4	44
R1932.19000	HS 32 / 19 mm	32	19.000	36	60	49	4	44
R1932.20000	HS 32 / 20 mm	32	20.000	36	60	50	4	45
R1932.22000	HS 32 / 22 mm	32	22.000	36	60	50	4	45
R1932.25000	HS 32 / 25 mm	32	25.000	36	60	56	4	52
Reduction Sleeves HS 32-CF								
R1932.06002	HS 32-CF / 6 mm	32	6.000	36	60	36	4	34
R1932.08002	HS 32-CF / 8 mm	32	8.000	36	60	36	4	35
R1932.10002	HS 32-CF / 10 mm	32	10.000	36	60	40	4	36
R1932.12002	HS 32-CF / 12 mm	32	12.000	36	60	45	4	41
R1932.14002	HS 32-CF / 14 mm	32	14.000	36	60	46	4	43
R1932.16002	HS 32-CF / 16 mm	32	16.000	36	60	48	4	44
R1932.18002	HS 32-CF / 18 mm	32	18.000	36	60	49	4	44
R1932.20002	HS 32-CF / 20 mm	32	20.000	36	60	50	4	45
R1932.25002	HS 32-CF / 25 mm	32	25.000	36	60	56	4	52

*) Minimum tool insertion depth (in mm) to ensure correct sealing effect for HS sleeves or correct periphery cooling for HS-CF sleeves.

Reduction Sleeves Inch to inch

mm to inch

Reduction Sleeves inch to inch								
Part no.	Item description	D2 inch	D1 inch	D3 inch	L1 inch	L2 inch	L3 inch	Min. tool insert depth*
Reduction Sleeves HS 1/2"								
R1913.03182	HS 1/2" / 1/8"	0.500	0.1250	0.630	1.575	1.142	0.157	26
R1913.04762	HS 1/2" / 3/16"	0.500	0.1875	0.630	1.575	1.142	0.157	28
R1913.06352	HS 1/2" / 1/4"	0.500	0.2500	0.630	1.575	1.417	0.157	34
R1913.07942	HS 1/2" / 5/16"	0.500	0.3125	0.630	1.575	1.457	0.157	34
R1913.09522	HS 1/2" / 3/8"	0.500	0.3750	0.630	1.575	1.575	0.157	37
Reduction Sleeves HS 1/2"-CF								
R1913.03183	HS 1/2"-CF / 1/8"	0.500	0.1250	0.630	1.575	1.142	0.157	26
R1913.06353	HS 1/2"-CF / 1/4"	0.500	0.2500	0.630	1.575	1.417	0.157	26
R1913.09523	HS 1/2"-CF / 3/8"	0.500	0.3750	0.630	1.575	1.575	0.157	37
Reduction Sleeves HS 3/4"								
R1919.03182	HS 3/4" / 1/8"	0.750	0.1250	0.984	1.969	1.102	0.157	25
R1919.04762	HS 3/4" / 3/16"	0.750	0.1875	0.984	1.969	1.102	0.157	25
R1919.06352	HS 3/4" / 1/4"	0.750	0.2500	0.984	1.969	1.417	0.157	34
R1919.07942	HS 3/4" / 5/16"	0.750	0.3125	0.984	1.969	1.457	0.157	35
R1919.09522	HS 3/4" / 3/8"	0.750	0.3750	0.984	1.969	1.417	0.157	35
R1919.11112	HS 3/4" / 7/16"	0.750	0.4375	0.984	1.969	1.575	0.157	37
R1919.12702	HS 3/4" / 1/2"	0.750	0.5000	0.984	1.969	1.772	0.157	42
R1919.14292	HS 3/4" / 9/16"	0.750	0.5625	0.984	1.969	1.772	0.157	42
R1919.15882	HS 3/4" / 5/8"	0.750	0.6250	0.984	1.969	1.890	0.157	44
Reduction Sleeves HS 3/4"-CF								
R1919.06353	HS 3/4"-CF / 1/4"	0.750	0.2500	0.984	1.969	1.417	0.157	34
R1919.09523	HS 3/4"-CF / 3/8"	0.750	0.3750	0.984	1.969	1.417	0.157	35
R1919.12703	HS 3/4"-CF / 1/2"	0.750	0.5000	0.984	1.969	1.772	0.157	42
R1919.15883	HS 3/4"-CF / 5/8"	0.750	0.6250	0.984	1.969	1.890	0.157	44
Reduction Sleeves HS 1"								
R1926.03182	HS 1" / 1/8"	1.000	0.1250	1.181	2.205	1.142	0.157	26
R1926.04762	HS 1" / 3/16"	1.000	0.1875	1.181	2.205	1.142	0.157	27
R1926.06352	HS 1" / 1/4"	1.000	0.2500	1.181	2.205	1.457	0.157	34
R1926.07942	HS 1" / 5/16"	1.000	0.3125	1.181	2.205	1.457	0.157	34
R1926.09522	HS 1" / 3/8"	1.000	0.3750	1.181	2.205	1.496	0.157	35
R1926.11112	HS 1" / 7/16"	1.000	0.4375	1.181	2.205	1.575	0.157	37
R1926.12702	HS 1" / 1/2"	1.000	0.5000	1.181	2.205	1.811	0.157	41
R1926.14292	HS 1" / 9/16"	1.000	0.5625	1.181	2.205	1.850	0.157	42
R1926.15882	HS 1" / 5/8"	1.000	0.6250	1.181	2.205	1.890	0.157	43
R1926.17462	HS 1" / 11/16"	1.000	0.6875	1.181	2.205	1.890	0.157	44
R1926.19052	HS 1" / 3/4"	1.000	0.7500	1.181	2.205	1.890	0.157	44
Reduction Sleeves HS 1"-CF								
R1926.06353	HS 1"-CF / 1/4"	1.000	0.2500	1.181	2.205	1.457	0.157	34
R1926.09523	HS 1"-CF / 3/8"	1.000	0.3750	1.181	2.205	1.496	0.157	35
R1926.12703	HS 1"-CF / 1/2"	1.000	0.5000	1.181	2.205	1.811	0.157	41
R1926.15883	HS 1"-CF / 5/8"	1.000	0.6250	1.181	2.205	1.890	0.157	43
R1926.19053	HS 1"-CF / 3/4"	1.000	0.7500	1.181	2.205	1.890	0.157	44
Reduction Sleeves HS 1 1/4"								
R1931.04762	HS 1 1/4" / 3/16"	1.250	0.1875	1.417	2.362	1.142	0.157	26
R1931.06352	HS 1 1/4" / 1/4"	1.250	0.2500	1.417	2.362	1.417	0.157	34
R1931.07942	HS 1 1/4" / 5/16"	1.250	0.3125	1.417	2.362	1.417	0.157	35
R1931.09522	HS 1 1/4" / 3/8"	1.250	0.3750	1.417	2.362	1.457	0.157	35
R1931.11112	HS 1 1/4" / 7/16"	1.250	0.4375	1.417	2.362	1.772	0.157	36
R1931.12702	HS 1 1/4" / 1/2"	1.250	0.5000	1.417	2.362	1.772	0.157	42
R1931.14292	HS 1 1/4" / 9/16"	1.250	0.5625	1.417	2.362	1.811	0.157	43
R1931.15882	HS 1 1/4" / 5/8"	1.250	0.6250	1.417	2.362	1.811	0.157	44
R1931.17462	HS 1 1/4" / 11/16"	1.250	0.6875	1.417	2.362	1.890	0.157	44
R1931.19052	HS 1 1/4" / 3/4"	1.250	0.7500	1.417	2.362	1.969	0.157	44
R1931.25402	HS 1 1/4" / 1"	1.250	1.000	1.417	2.362	2.205	0.157	52
Reduction Sleeves HS 1 1/4"-CF								
R1931.12703	HS 1 1/4"-CF / 1/2"	1.250	0.5000	1.417	2.362	1.772	0.157	42
R1931.15883	HS 1 1/4"-CF / 5/8"	1.250	0.6250	1.417	2.362	1.811	0.157	44
R1931.19053	HS 1 1/4"-CF / 3/4"	1.250	0.7500	1.417	2.362	1.969	0.157	44
R1931.25403	HS 1 1/4"-CF / 1"	1.250	1.000	1.417	2.362	2.205	0.157	52

Reduction Sleeves mm to inch								
Part no.	Item description	D2 mm	D1 inch	D3 mm	L1 mm	L2 mm	L3 mm	Min. tool insert depth*
Reduction Sleeves HS 12								
R1912.03181	HS 12 / 1/8"	12	0.1250	16	40	29	4	25
R1912.04761	HS 12 / 3/16"	12	0.1875	16	40	30	4	28
R1912.06351	HS 12 / 1/4"	12	0.2500	16	40	36	4	34
R1912.07941	HS 12 / 5/16"	12	0.3125	16	40	36	4	34
R1912.09521	HS 12 / 3/8"	12	0.3750	16	40	37	4	37
Reduction Sleeves HS 12-CF								
R1912.03183	HS 12-CF / 1/8"	12	0.1250	16	40	29	4	25
R1912.06353	HS 12-CF / 1/4"	12	0.2500	16	40	36	4	34
Reduction Sleeves HS 20								
R1920.03181	HS 20 / 1/8"	20	0.1250	25	50	28	4	22
R1920.04761	HS 20 / 3/16"	20	0.1875	25	50	28	4	25
R1920.06351	HS 20 / 1/4"	20	0.2500	25	50	36	4	34
R1920.07941	HS 20 / 5/16"	20	0.3125	25	50	37	4	35
R1920.09521	HS 20 / 3/8"	20	0.3750	25	50	36	4	35
R1920.11111	HS 20 / 7/16"	20	0.4375	25	50	40	4	37
R1920.12701	HS 20 / 1/2"	20	0.5000	25	50	45	4	42
R1920.14291	HS 20 / 9/16"	20	0.5625	25	50	45	4	42
R1920.15881	HS 20 / 5/8"	20	0.6250	25	50	48	4	44
Reduction Sleeves HS 25								
R1925.03181	HS 25 / 1/8"	25	0.1250	30	56	29	4	24
R1925.06351	HS 25 / 1/4"	25	0.2500	30	56	37	4	34
R1925.07941	HS 25 / 5/16"	25	0.3125	30	56	37	4	34
R1925.09521	HS 25 / 3/8"	25	0.3750	30	56	38	4	35
R1925.11111	HS 25 / 7/16"	25	0.4375	30	56	40	4	37
R1925.12701	HS 25 / 1/2"	25	0.5000	30	56	46	4	41
R1925.14291	HS 25 / 9/16"	25	0.5625	30	56	47	4	42
R1925.15881	HS 25 / 5/8"	25	0.6250	30	56	48	4	43
R1925.17461	HS 25 / 11/16"	25	0.6875	30	56	48	4	43
R1925.19051	HS 25 / 3/4"	25	0.7500	30	56	48	4	44
R1925.20631	HS 25 / 13/16"	25	0.8125	30	56	50	4	44
Reduction Sleeves HS 32								
R1932.04761	HS 32 / 3/16"	32	0.1875	36	60	29	4	26
R1932.06351	HS 32 / 1/4"	32	0.2500	36	60	36	4	34
R1932.07941	HS 32 / 5/16"	32	0.3125	36	60	36	4	35
R1932.09521	HS 32 / 3/8"	32	0.3750	36	60	37	4	35
R1932.11111	HS 32 / 7/16"	32	0.4375	36	60	45	4	36
R1932.12701	HS 32 / 1/2"	32	0.5000	36	60	45	4	42
R1932.14291	HS 32 / 9/16"	32	0.5625	36	60	46	4	43
R1932.15881	HS 32 / 5/8"	32	0.6250	36	60	46	4	44
R1932.17461	HS 32 / 11/16"	32	0.6875	36	60	48	4	44
R1932.19051	HS 32 / 3/4"	32	0.7500	36	60	50	4	44
R1932.20631	HS 32 / 13/16"	32	0.8125	36	60	50	4	45
R1932.22221	HS 32 / 7/8"	32	0.8750	36	60	50	4	45
R1932.23811	HS 32 / 15/16"	32	0.9375	36	60	52	4	45
R1932.25401	HS 32 / 1"	32	1.000	36	60	56	4	52

*) Minimum tool insertion depth (in mm) to ensure correct sealing effect for HS sleeves or correct periphery cooling for HS-CF sleeves.

Chip covers for reduction sleeves CC

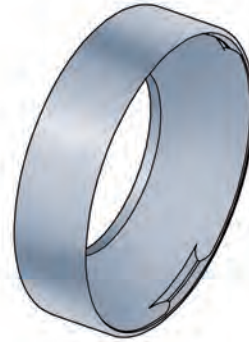

Our chip cover is ideally suited for the removal of chips. The cover can simply be clicked-in at the head of our reduction sleeves.

Chip covers				
Part no.	Type	Fits	[mm]	[inch]
Chip covers for reduction sleeves CC-HS 12				
R7331.04200	CC-HS 12 – 1/2" / Ø 4.0 mm	HS 12, HS 1/2"	3–4	1/8"
R7331.06600	CC-HS 12 – 1/2" / Ø 6.0 mm	HS 12, HS 1/2"	5–6	3/16"–1/4"
R7331.10200	CC-HS 12 – 1/2" / Ø 10.0 mm	HS 12, HS 1/2"	7–10	5/16"–3/8"
Chip covers for reduction sleeves CC-HS 20				
R7333.04200	CC-HS 20 – 3/4" / Ø 4.0 mm	HS 20, HS 3/4"	3–4	1/8"
R7333.06600	CC-HS 20 – 3/4" / Ø 6.0 mm	HS 20, HS 3/4"	5–6	1/16"–1/4"
R7333.10200	CC-HS 20 – 3/4" / Ø 10.0 mm	HS 20, HS 3/4"	7–10	5/16"–3/8"
R7333.14200	CC-HS 20 – 3/4" / Ø 14.0 mm	HS 20, HS 3/4"	11–14	7/16"–1/2"
R7333.16200	CC-HS 20 – 3/4" / Ø 16.0 mm	HS 20, HS 3/4"	15–16	9/16"–5/8"
R7333.18200	CC-HS 20 – 3/4" / Ø 18.0 mm	HS 20, HS 3/4"	18	–

Assembly: Assemble the sleeve and chip cover before inserting the tool and loading the sleeve into the holder. This ensures easier assembly and protects tools and fingers.

Fit: The chip cover allows a small gap between the holder face and sleeve lip, ensuring proper face contact without interference.

Precision: The cover's slightly larger hole does not affect runout or clamping force.

Removal: Use extractor wrench for easy disassembly, as removal may otherwise be difficult.

Accessories Torque wrench and Extractor



Comparison of Transmittable Torque at Ø 20 mm

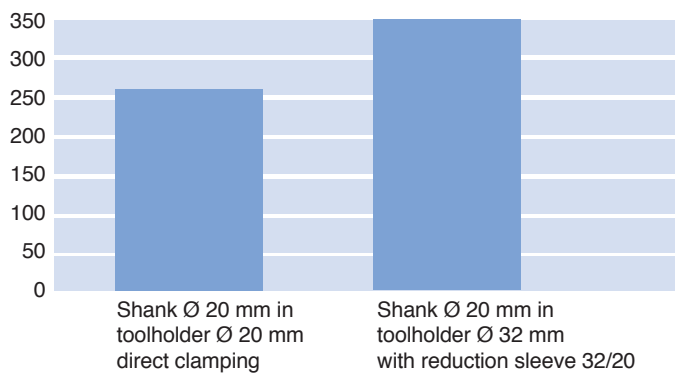

Torque wrench

Use torque wrench to ensure correct tightening independent on user. Should be used with all HYDRO-FIX® holders.

Item description	Tightening torque:		Part no.
	Nm	ft · lb	
Torque wrench (3 mm Hex)	1.8	1.3	19070
Torque wrench (4 mm Hex)	6	4.4	19055
Torque wrench (5 mm Hex)	6	4.4	19050
Torque wrench (8 mm Hex)	10	7.4	19054

Extractor

Item description	Part no.	For Sizes	A	B
			[mm]	[mm]
EHS 12 - 1/2"	E7321.12000	HS 12	24.6	100
EHS 20 - 3/4"	E7321.20000	HS 20	38.0	160
EHS 25 - 1"	E7321.25000	HS 25	51.0	180
EHS 32 - 1 1/4"	E7321.32000	HS 32	63.0	200

- Improper assembly can damage the concentricity of the reduction sleeve.
- Insert tools the full length of the reduction sleeve.
- Tool shank h6 or h7 can be used.
- Do not clamp reduction sleeve without a tool. Reduction Sleeve will be damaged.

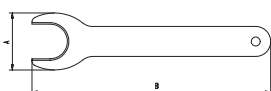
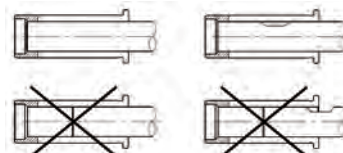

The extractor helps to remove the reduction sleeve from the clamping unit.



*More Hydraulic high
precision toolholders
- see our main catalogue*

Examples: Holders for Small parts machining

ETP HYDRO-GRIP®
HSK40 Form A

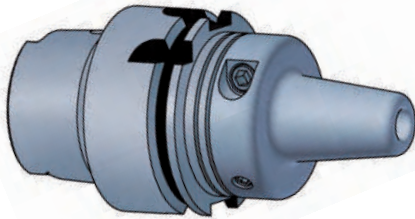

ETP HYDRO-GRIP®
HSK40 Form E

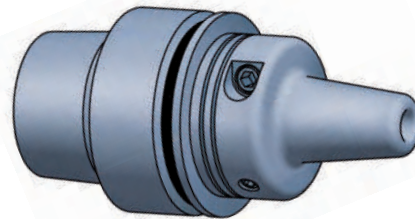

Plaza del Vapor 7 A - Pol. Ind. Les Guixeres
08915 Badalona, Barcelona
www.sumecsl.com | 93 399 30 15
sumecsl@sumecsl.com