

BENEFITS & FEATURES

- Turn ER holders and driven Tools into hydraulic
- Easy handling and precision
- Excellent repeatability
- Adjustability of run-out



 ER

ETP ECOGRIP™ ER

Make your ER holders and driven tools hydraulic and enjoy multiple benefits

With ETP ECOGRIP ER you can easily turn your standard ER collet holders and driven tools into high precision hydraulic holders. Thus you can easily enjoy all the

positive benefits of hydraulic clamping such as easy handling and precision, at an impressive competitive price level. This enables more users to benefit from decrease

tool wear and increased productivity, when compared to using ER collet holders. With the use of the three axial screws an adjustability of the run-out is achieved.

ETP ECOGRIP™ ER

For outer threaded toolholders and driven tools

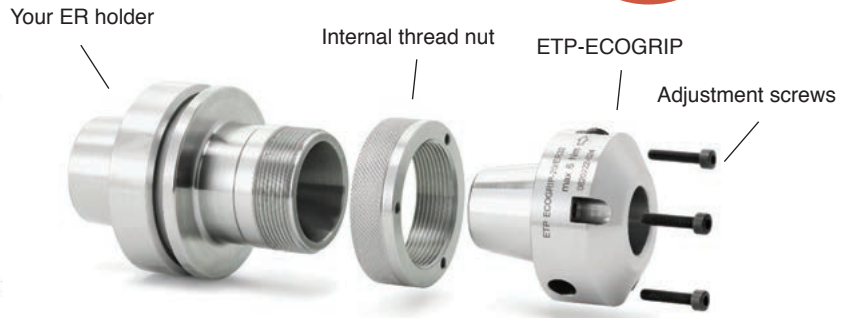
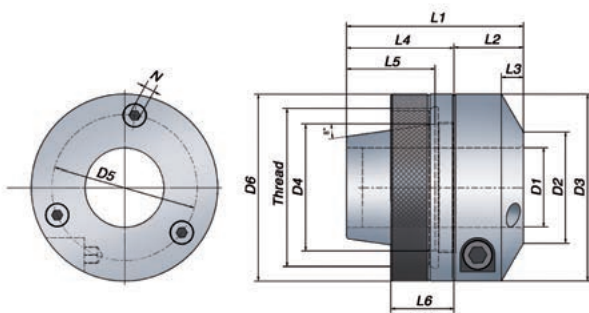

Metric range

Technical Specification																				
ER size	Part no.	Item description	Dimensions, mm											Adjustment screws				Internal thread nut		T* Nm
			D1	D2	D3	D4	L1	L2	L3	L4	L5	D5	No.	Dim.	N	D6	L6	Thread		
● 16	686845	ECOGRIP-6/ER16	6	16	34	16	30	14	5	16	14	28	2	M3x16*	2.5	34	10	M22x1.5	6-14	
● 16	686846	ECOGRIP-6/ERM16	6	16	34	16	30	14	5	16	14	28	2	M3x16*	2.5	34	10	M19x1	6-14	
○ 16	704952	ECOGRIP-8/ER16	8	18	36	16	30	14	5	16	14	28	2	M3x16*	2.5	36	10	M22x1.5	14 - 35	
○ 16	705718	ECOGRIP-8/ERM16	8	18	36	16	30	14	5	16	14	28	2	M3x16*	2.5	34	10	M19x1	14 - 35	
● 20	686855	ECOGRIP-12/ER20	12	22	43.5	20	40	24	7	16	14	34	3	M4x20	3	43.5	12	M25x1.5	50-90	
● 20	686856	ECOGRIP-12/ERM20	12	22	43.5	20	40	24	7	16	14	34	3	M4x20	3	43.5	12	M24x1	50-90	
● 25	686905	ECOGRIP-12/ER25	12	26	48	25	46	26	7	20	18	41	3	M4x20	3	48	13	M32x1.5	50-90	
● 25	686906	ECOGRIP-12/ERM25	12	26	48	25	46	26	7	20	18	41	3	M4x20	3	48	13	M30x1	50-90	
● 25	686875	ECOGRIP-16/ER25	16	26	48	25	46	26	7	20	18	41	3	M4x20	3	48	13	M32x1.5	120-200	
● 25	686876	ECOGRIP-16/ERM25	16	26	48	25	46	26	7	20	18	41	3	M4x20	3	48	13	M30x1	120-200	
● 32	686865	ECOGRIP-20/ER32	20	30	52	32	52	25.5	7	26.5	24.5	45	3	M4x20	3	52	15	M40x1.5	230-370	
● 40	686885	ECOGRIP-25/ER40	25	35	59	40	56	22	7	34	28	46	3	M4x16	3	59	20	M50x1.5	420-600	
○ 50	686895	ECOGRIP-32/ER50**	32	42	69.5	50	60	22	7	38	32	56	3	M4x15	3	78	20	M64x2	660-1000	

Inch range

Technical Specification																				
ER size	Part no.	Item description	Dimensions, inch											Adjustment screws				Internal thread nut		T* ft-lb
			D1	D2	D3	D4	L1	L2	L3	L4	L5	D5	No.	Dim.	N	D6	L6	Thread		
● 16	686945	ECOGRIP-1/4"/ER16	0.250	0.630	1.339	0.630	1.181	0.551	0.197	0.630	0.551	1.102	2	M3x16*	0.098	1.339	0.394	M22x1.5	4.4-10	
● 20	686955	ECOGRIP-1/2"/ER20	0.500	0.866	1.713	0.787	1.575	0.945	0.276	0.630	0.551	1.339	3	M4x20	0.118	1.713	0.472	M25x1.5	37-66	
● 20	686956	ECOGRIP-1/2"/ERM20	0.500	0.866	1.713	0.787	1.575	0.945	0.276	0.630	0.551	1.339	3	M4x20	0.118	1.713	0.472	M24x1	37-66	
● 25	687005	ECOGRIP-1/2"/ER25	0.500	1.024	1.890	0.984	1.811	1.024	0.276	0.787	0.709	1.614	3	M4x20	0.118	1.890	0.512	M32x1.5	37-66	
● 25	686975	ECOGRIP-5/8"/ER25	0.625	1.024	1.890	0.984	1.811	1.024	0.276	0.787	0.709	1.614	3	M4x20	0.118	1.890	0.512	M32x1.5	89-148	
● 32	686965	ECOGRIP-3/4"/ER32	0.750	1.181	2.047	1.260	2.047	1.004	0.276	1.043	0.965	1.772	3	M4x20	0.118	2.047	0.591	M40x1.5	170-273	
● 40	686985	ECOGRIP-1"/ER40	1.000	1.378	2.323	1.575	2.205	0.866	0.276	1.339	1.102	1.811	3	M4x16	0.118	2.323	0.787	M50x1.5	310-443	
○ 50	686995	ECOGRIP-1 1/4"/ER50**	1.250	1.654	2.736	1.969	2.362	0.866	0.276	1.496	1.260	2.205	3	M4x15	0.118	3.071	0.787	M64x2	487-738	

*) This size ECOGRIP ER has 2x M3x16 adjustment screws located 180 degrees apart. It also has an additional 2x M5x8 adjustment screws, located 180 degrees apart, at the back of the thread nut.

***) The thread nut width L6 of this size ECOGRIP ER is 20 mm. The thread depth is however only 15 mm.

*) T = Min. and Max transmittable torque using a h6 cylindrical tool, full depth insert. For additional information see section Technical Information.

- From stock
- On request

Information:

- Runout accuracy - adjustable!
When mounted correctly, an initial runout of approx. 0.020 mm is achieved. Adjust runout further by lightly tightening on the adjustment screws until your desired runout is achieved.
- Tool shank h6 or h7 can be used
- Balanced by design. For use above 5 - 10 000 rpm – we recommend individual balancing.

Accessories:

Use preset Torque Wrench, 6 Nm, to ensure correct mounting of tools. Part no. 19050. For ER16 Use Torque wrench Part no. 19055.

ETP ECOGRIP ER can be used with reducing sleeves. For additional information see section Accessories.



ETP ECOGRIP™ ER

For inner threaded driven tools

Adjustable holder

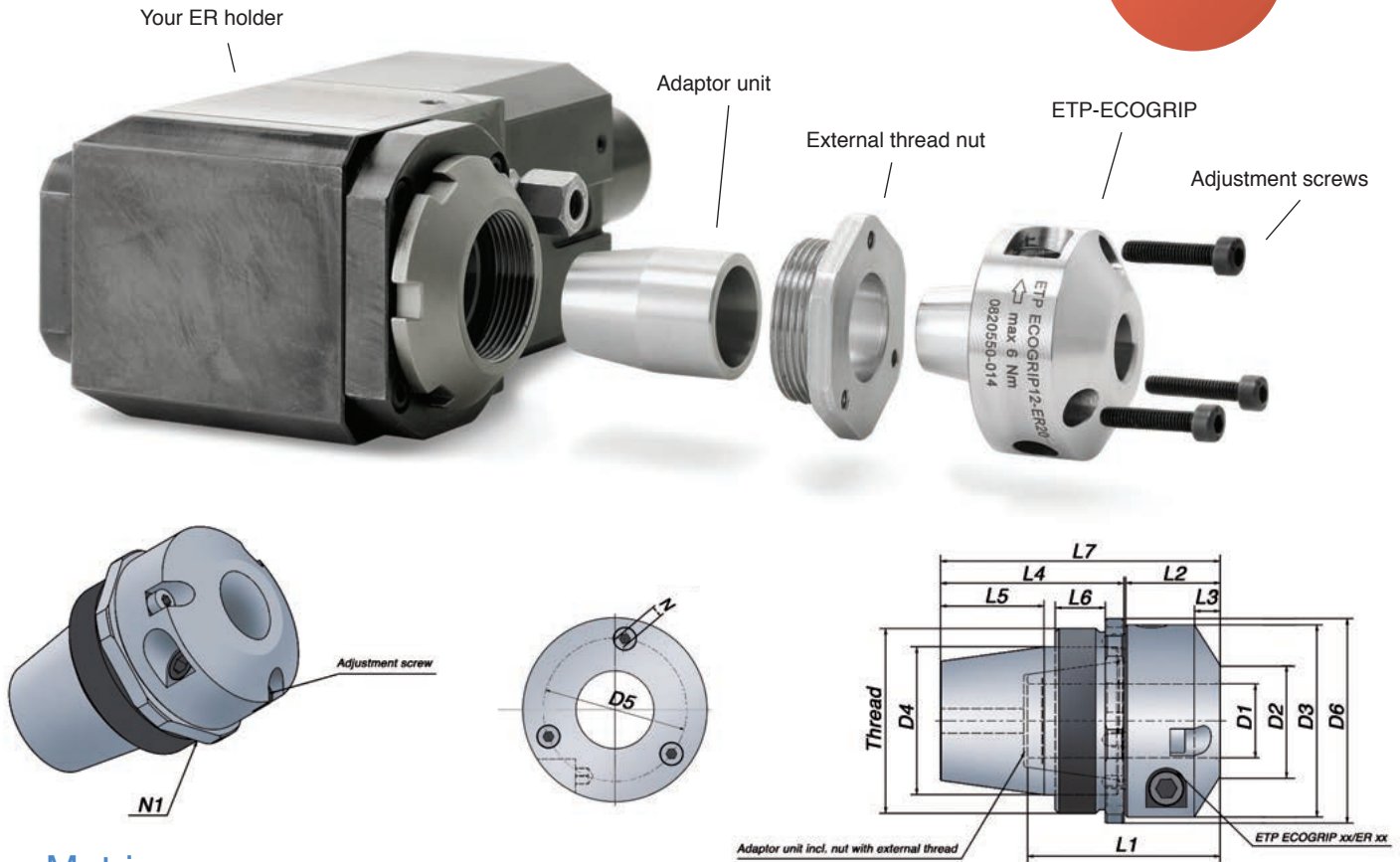

Metric range

Technical Specification		Dimensions, mm											Adjustment screws				External thread nut					
ER size	Part no.	Item description	D1	D2	D3	D4	L1	L2	L3	L4	L5	L7	D5	No.	Dim.	N	D6	L6	Thread	N1	Tt Nm	T* Nm
● 25	687310	ECOGRIP-12/ER20-25	12	22	43.5	25	40	24	7	36	18	60.5	34	3	M4x16	3	43.5	10	M32x1.5	40	50	50-90
● 32	687320	ECOGRIP-12/ER25-32	12	26	48	32	46	26	7	44.5	24.5	71	41	3	M4x16	3	48	12	M40x1.5	44	104	50-90
●	687330	ECOGRIP-16/ER25-32	16	26	48	32	46	26	7	44.5	24.5	71	41	3	M4x16	3	48	12	M40x1.5	44	104	120-200
● 40	687340	ECOGRIP-20/ER32-40	20	30	52	40	52	25.5	7	49.5	28	75.5	45	3	M4x16	3	56	13.5	M50x1.5	52	128	230-370

Inch range

Technical Specification		Dimensions, inch											Adjustment screws				External thread nut					
ER size	Part no.	Item description	D1	D2	D3	D4	L1	L2	L3	L4	L5	L7	D5	No.	Dim.	N	D6	L6	Thread	N1	Tt Nm	T* ft-lb
● 25	687410	ECOGRIP-1/2"/ER20-25	0.500	0.866	1.713	0.984	1.575	0.945	0.276	1.417	0.709	2.382	1.339	3	M4x16	0.118	1.713	0.394	M32x1.5	1.575	50	37-66
● 32	687420	ECOGRIP-1/2"/ER25-32	0.500	1.024	1.890	1.260	1.811	1.024	0.276	1.752	0.965	2.795	1.614	3	M4x16	0.118	1.890	0.472	M40x1.5	1.732	104	37-66
●	687430	ECOGRIP-5/8"/ER25-32	0.625	1.024	1.890	1.260	1.811	1.024	0.276	1.752	0.965	2.795	1.614	3	M4x16	0.118	1.890	0.472	M40x1.5	1.732	104	89-148
● 40	687440	ECOGRIP-3/4"/ER32-40	0.750	1.181	2.047	1.575	2.047	1.004	0.276	1.949	1.102	2.972	1.772	3	M4x16	0.118	2.205	0.531	M50x1.5	2.047	128	170-273

Tt: Recommended tightening torque in Nm for the External thread nut.

*) T = Min. and Max transmittable torque using a h6 cylindrical tool, full depth insert. For additional information see section Technical Information.

- From stock
- On request

Information:

- Runout accuracy - adjustable!
When mounted correctly, an initial runout of approx. 0.020 mm is achieved. Adjust runout further by lightly tightening on the adjustment screws until your desired runout is achieved.
- Tool shank h6 or h7 can be used
- Balanced by design

Accessories:

Use preset Torque Wrench, 6 Nm, to ensure correct mounting of tools. Part no. 19050.

ETP ECOGRIP ER can be used with reducing sleeves.
For additional information see section Accessories.



Mounting procedure

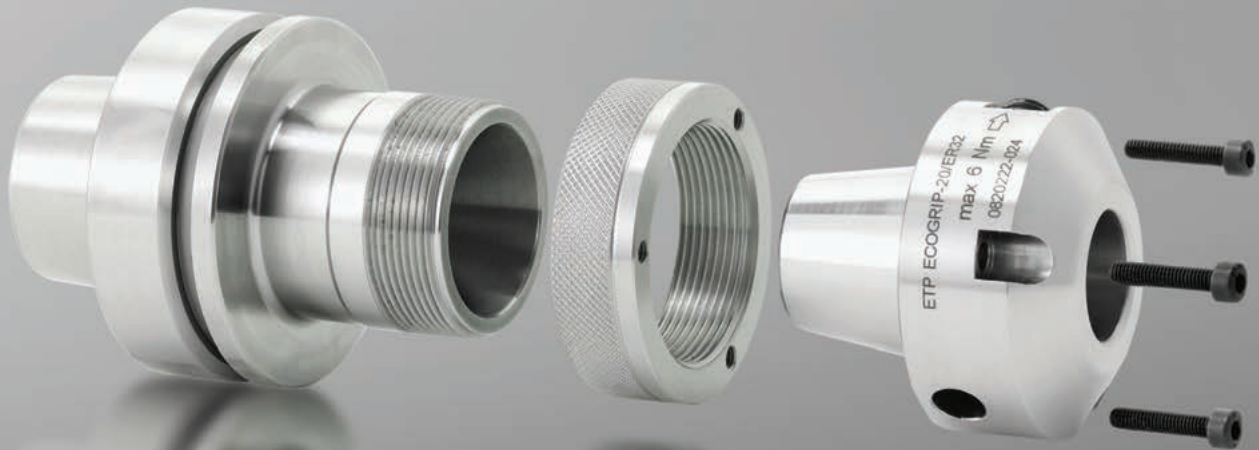

1. Mount the ring nut on the ER holder
2. Mount the ETP ECOGRIP ER in the holder and twist to seal
3. Mount the adjustment screws

When mounted correctly, an initial runout of 0.020 mm is achieved.

Then adjust the runout further by lightly tightening on the adjustment screws until your desired runout is achieved.

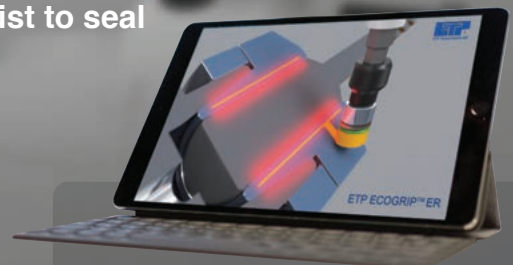

Watch ETP ECOGRIP ER on YouTube

Accessories

Torque wrench

Use the torque wrench to ensure correct and consistent tightening by different users. This wrench should be used with all HYDRO-GRIP and ECOGRIP holders.

Torque: 6 Nm.



Item description	Tightening torque: Nm	Part no.
● HYDRO-GRIP Torque wrench (5 mm Hex)	6	19050
● HYDRO-GRIP Torque wrench (4 mm Hex)	6	19055

- From stock
- On request

Reduction Sleeves for ETP Toolholders

All ETP ECOGRIP ER holders can be used with reduction sleeves.

For complete available assortment see our main catalogue - Metalworking.



Plaza del Vapor, 7 A Pol. Les Guixeres
08915 Badalona, Barcelona
Tel. 93 399 30 15
www.sumecsl.com
sumecsl@sumecsl.com